



WHAT'S NEW IN MASTERCAM 2017

April 2016

POWERED BY MASTERCAM'S
DYNAMIC MOTION™ TECHNOLOGY 

Mastercam®
Be Dynamic.

WHAT'S NEW IN MASTERCAM 2017

April 2016

Copyright © 2016 CNC Software, Inc. – All rights reserved.

Software: Mastercam 2017

Terms of Use

Use of this document is subject to the Mastercam End User License Agreement. A copy of the Mastercam End User License Agreement is included with the Mastercam product package of which this document is part. The Mastercam End User License Agreement can also be found at:

<http://www.mastercam.com/companyinfo/legal/LicenseAgreement.aspx>

Be sure you have the latest information!

Information might have changed or been added since this document was published. The latest version of the document is installed with Mastercam or can be obtained from your local Reseller. A ReadMe file (ReadMe.PDF) – installed with each release – includes the latest information about Mastercam features and enhancements.

TABLE OF CONTENTS

Introduction	11
New Mastercam Look and Feel	11
Mastercam Documentation	15
Contact Us	16
Mastercam Resources	16
General Enhancements	19
Analyze Enhancements	19
Analyze Trimmed Spline	19
Analyze Dynamic Enhancements	20
Appearance Enhancements	21
Dimmed and No Hidden Wireframe View	21
Outline Shaded Support for Polygon Mesh/STL	22
Rendered Modes	23
Solid Edges in No Hidden Wireframe Mode	24
ATP Enhancements	24
Chain Sorting	24
Z Position	25
Automatic Support for GDT Data	25

Unigraphics/NX and STEP Files	25
CATIA Version 5	26
Code Expert Enhancements	27
Individual Fonts and Colors in NC Configuration	27
Tool Change Indicator	28
Character Encoding to Opened and Saved Text Based Files	30
Improve Communications Options for CIMCO	32
General Toolpath Enhancements	32
Drag and Drop Operations Import	32
Drill Point Selection	33
Ghosted Operations Support	33
Reverse Chains Order	34
Preventing Changes to Processing Toolpaths	34
Toolpath Transform Enhancements	36
Graphics Window Enhancements	38
Axes Display Enhancements	38
Interactive Gview Gnomon for Dynamic Planes	39
Updated Grid Functions	40
Levels Manager Enhancements	41
Column Reordering	42
Hide or Display Columns	43

Hide Level Properties	43
Mastercam Add-On Enhancements	44
STL Heal C-Hook	44
Support for OnShape Documents	44
Mastercam File Extensions	46
Mastercam Simulator Enhancements	47
Auto Start	47
Fixture Support Enhancements	48
Printing	48
Record Video	49
Reverse Direction for Clipping Planes	49
Synchronize Views	49
Printing Multiple Copies	50
Migration of Custom Machine Simulation Files	51
Multiple Instances Now Supported	51
Planes Manager Enhancements	52
Always Display Gnomon	53
Hide or Display Columns	53
Hide Planes Properties	54
New G Column to Set Gview in Planes Manager	54
New Follow Rule	54

Origin Enhancements	55
Reorder Columns	56
Recent Functions	57
Setup Sheet Enhancements	58
New Setup Sheet XML Tags	58
Option to Clean Up XML Folder	58
Save Images in Nesting Reports	59
System Configuration Enhancements	59
Chaining Arrow Size Options	59
Get Defaults from Previous Operation	60
Import Sketch Data from SOLIDWORKS	61
New View Settings Page	63
Screen Page Enhancements	63
Set Tool Colors	65
Solid Preview Option	65
Viewsheet Enhancements	66
Create and Save Bookmarks from Planes	66
Delete Multiple Viewsheets	67
Removed the Concept of "Main" Viewsheet	67
Zip2Go Enhancements	67
Design Enhancements	69

Bounding Box Center Point	69
Drafting Enhancements	70
Drafting formatting	70
Edit text heights for both notes and dimensions	71
Plane Selection Enhancements	72
Solids Enhancements	73
Disassemble Enhancements	73
Keep Name After History is Removed	74
Optimize	74
Pick Solid Face Color	74
Preprocess Solid	75
Repair Small Faces	75
Solid Impression	76
Transform Enhancements	77
Transform Dynamic AutoCursor Support	77
Dynamic Gnomon Editing	79
Scale	81
Stretch	83
Wireframe Enhancements	84
User Interface Changes	84
Sharp Corner Smoothing Added to Spline From Curves	85

Break at Points	85
Point and Line Dynamic Split into Two Functions	85
Refit Spline	86
Relief Fillet Style	86
Untrim Spline	87
Persisting Values for Create Letters	87
Tool Enhancements	89
Add and Remove Manufacturers and Tool Grades	89
Custom Tool Display	90
High Feed Mill Tool Type	92
Import 3D STEP File	93
NCI Parameter for Tool Assembly Name	94
Overall Length	95
Similar Tool Warning	96
Thread Pitch	96
Tool List Enhancements	97
Column Display	97
Display Mode Setting	98
Tool Migration Warning	99
Tool Projection	100
Mill Enhancements	103

2D Enhancements	103
Dynamic Mill Line of Sight	103
Modeless Chain Options and Chaining Dialog Box	104
Region Chaining Preview	104
Toolpath Preview	104
3D Enhancements	105
Maximum Stock Engagement	105
Optimized Raster Motion	106
Scallop Processing Time	107
Trim to Stock/Rest Material Page Changes	107
Multiaxis Enhancements	108
Angle Step Value	108
Multiaxis Drill	108
Interface Changes and Toolpath Consolidation	109
Point and Line Associativity	110
Point Sorting	110
Roughing Page Consolidation	111
Rotary Advanced	111
Stock Page Consolidation	112
Lathe Enhancements	113
Align Solid Body (Lathe)	113

Chip Break	114
Lathe Plane Enhancements	116
Display Mode	118
Lathe Stock Model Enhancements	119
TNRC Control for B-Axis Turning Operations	120
Mill-Turn Enhancements	121
Align Solid Body (Mill-Turn)	121
Application Guides in .machine Files	122
Job Setup Enhancements	122
Improved Handling of Position Changes	122
Improved Handling of Complex Part Geometry	122
Machine File Version Properties	123
Multi-Sessions and Multi-Machine Group Support	123
Multi-Station Tool Locators for Turrets	124
Reference Positions Enhancements	128
Allow Multiple Reference Return Locations	128
Add Optional Default Reference Position in POCO	128
View Control Options for Sync Manager	128

INTRODUCTION

Welcome to Mastercam 2017! Mastercam 2017 features new functionality focused on delivering speed and efficiency to your machining jobs. We are sure that you will benefit from what Mastercam 2017 has to offer you and your shop.

New Mastercam Look and Feel

Mastercam 2017 features a new ribbon interface, similar to the Microsoft Office products. The new interface capitalizes on your experience with other software, and uses that familiarity to make it easier to find the functions you need to complete your tasks.

The ribbon tabs group similar functions and display them in order from simple to more complex. Each tab relates to a type of activity, from creating wireframe geometry to generating toolpaths. Editing functions are on the same tab as creation functions, so you have all the tools you need when you need them.



The tabs also combine icons with text, making it easier to find the functions you need.

The **Machine** tab includes all of your machine types. Selecting a machine type displays a contextual tab that lists available toolpaths and related functions.

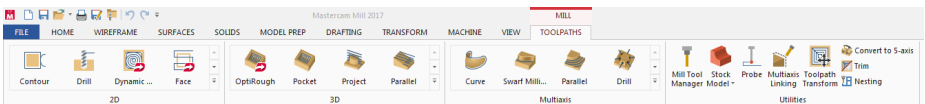

You can search through toolpath galleries that show icons with sample tool motion to help you decide which toolpath to use.

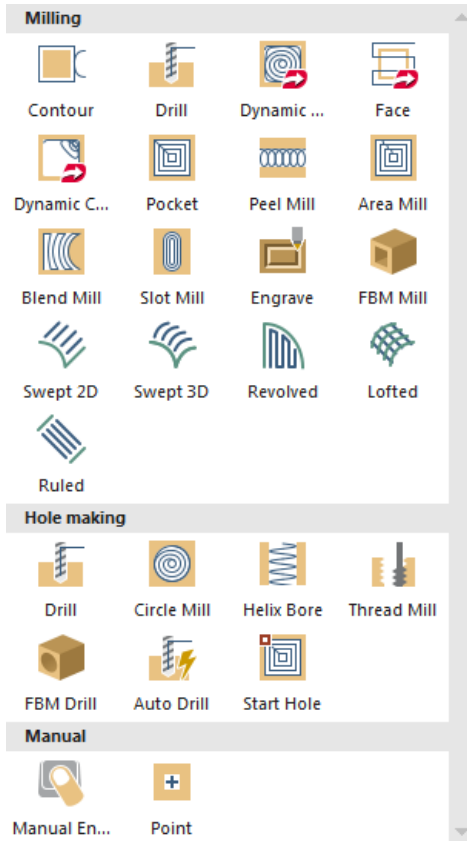

Click **File** to access the Backstage view, which contains all of your file management tools. You can access information about your current part file, customize your Mastercam environment, learn more about Mastercam with the Help and tutorials, and connect with the Mastercam community.

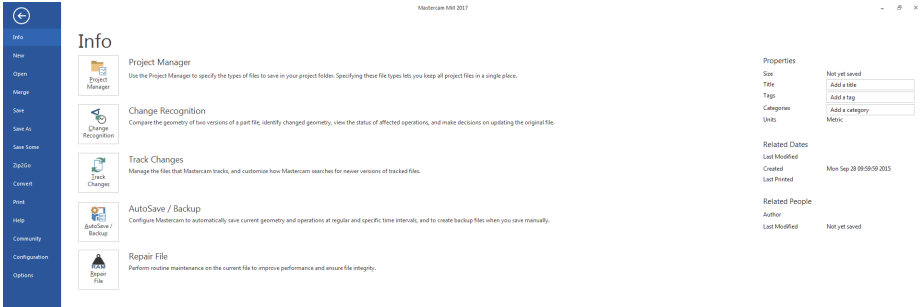

The Quick Access Toolbar contains a set of commands independent of the tab that is currently displayed. You can move the Quick Access Toolbar above or below the ribbon, and you can add or remove buttons as needed.

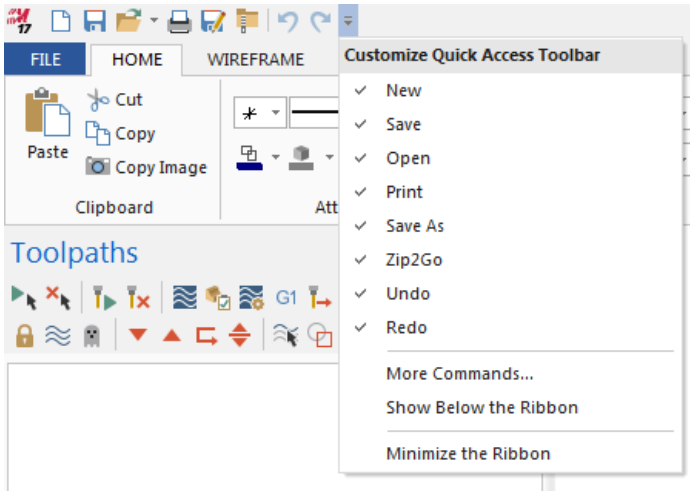

You can also right-click on a function in any of the tabs and add it to the Quick Access Toolbar by selecting **Add to Quick Access Toolbar**.

Right-click in the graphics window for easy access to all your entity attributes with the new mini-toolbar. Select the popout button on the right side of the mini-toolbar to anchor the toolbar permanently on the screen.

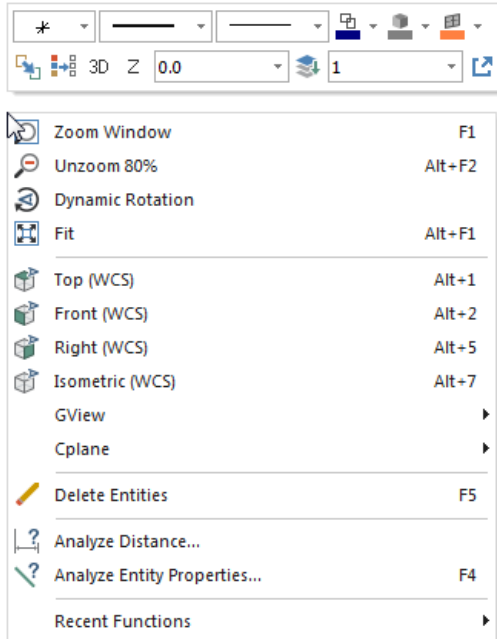

In addition, all of the selection functions are featured in the graphics window so you can access them when you need to.

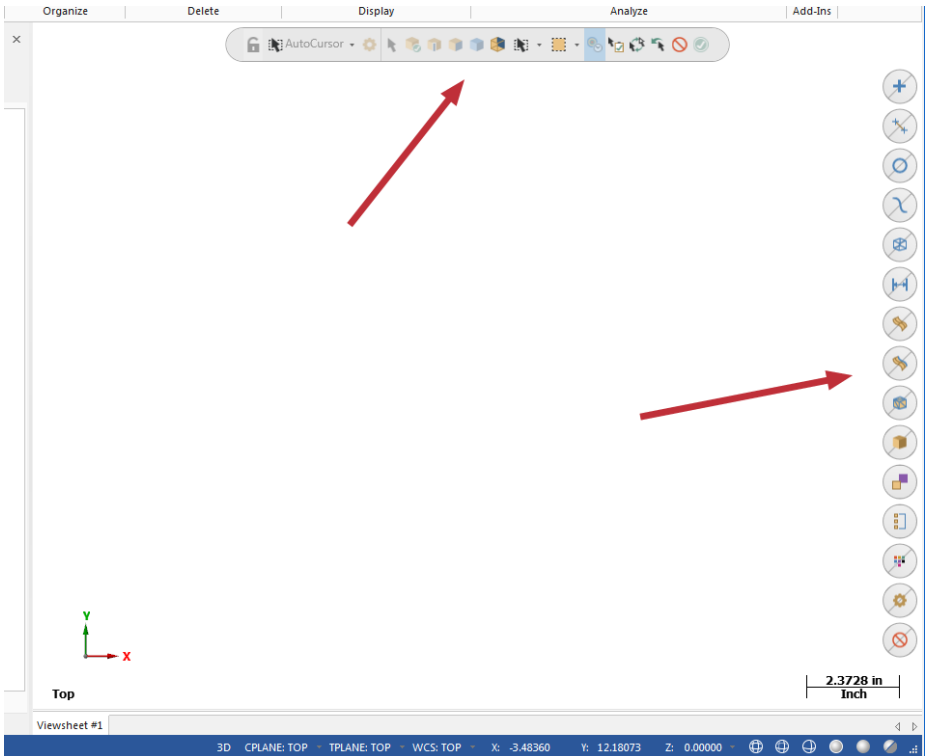

Mastercam Documentation

Mastercam installs the following documents in the \Documentation folder of your Mastercam 2017 installation:

- What's New in Mastercam 2017
- Mastercam 2017 Installation Guide
- Mastercam 2017 Administrator Guide

- Mastercam 2017 Transition Guide
- Mastercam 2017 Quick Reference Card
- Mastercam 2017 ReadMe

Contact Us

For questions about this or other Mastercam documentation, contact the Technical Documentation department by email at techdocs@mastercam.com.

Mastercam Resources

Enhance your Mastercam experience by using the following resources:

- *Mastercam Help*— Access Mastercam Help by selecting **Help, Contents** from Mastercam's **File** tab. Also, most dialog boxes and function panels feature a Help button that opens Mastercam Help directly to related information.
- *Mastercam Reseller*— Your local Mastercam Reseller can help with most questions about Mastercam.
- *Technical Support*—CNC Software's Technical Support department (860-875-5006 or support@mastercam.com) is open Monday through Friday from 8:00 a.m. to 5:30 p.m. USA Eastern Standard Time.
- *Mastercam Tutorials*—CNC offers a series of tutorials to help registered users become familiar with basic Mastercam features and functions. The Mastercam tutorial series is in continual development, with new modules added as we complete them. Visit our website, or select **Help, Tutorials** from the **File** tab.
- *Mastercam University*—CNC Software sponsors Mastercam University, an affordable online learning platform that gives you 24/7 access to Mastercam training materials. Take advantage of more than 180 videos to master your skills at your own pace and help prepare yourself for Mastercam Certification. For more information on Mastercam University,

please contact your Authorized Mastercam Reseller, visit [www.-mastercamu.com](http://www.mastercamu.com), or email training@mastercam.com.

- *Online communities*—You can find a wealth of information including many videos, at www.mastercam.com. For tech tips and the latest Mastercam news, follow us on Facebook (www.facebook.com/mastercam), Twitter (www.twitter.com/mastercam), or Google+ (plus.google.com/+mastercam). Visit our YouTube channel to see Mastercam in action (www.youtube.com/user/MastercamCadCam)!

Registered users can search for information or ask questions on the Mastercam Web forum, forum.mastercam.com, or use the knowledgebase at kb.mastercam.com. To register, select **Community, Link on Mastercam.com** from the **File** tab.

GENERAL ENHANCEMENTS

Analyze Enhancements

Analyze Trimmed Spline

Mastercam will now inform you if the selected spline is trimmed or not when using the **Analyze Entity** function, located on the **Home** tab.

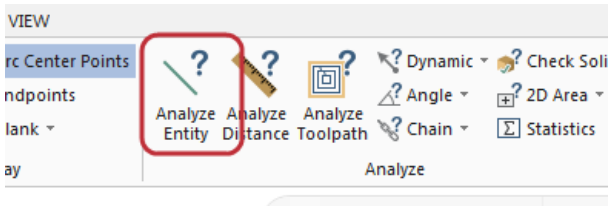

Analyze Dynamic Enhancements

The user interface for Analyze Dynamic has been improved for Mastercam 2017.

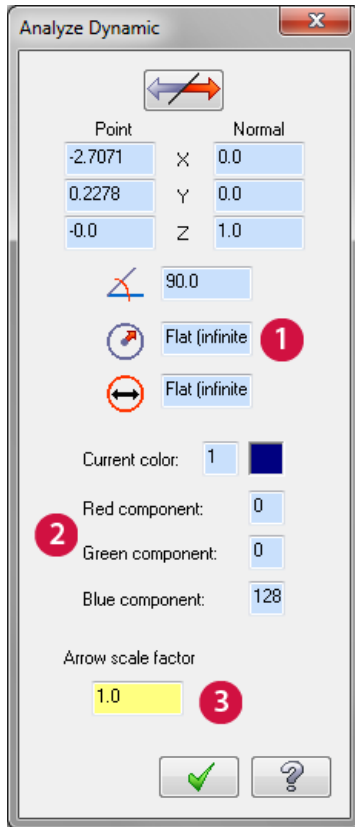

1. **Diameter readout:** Displays the diameter of an arc, face, or surface, making it easier for you to choose a maximum tool diameter for a curved area.
2. **Color and RGB information:** Displays the color and RGB information of the selected entity. This information can be used to communicate control tolerances and stock to leave.

3. **Arrow scale factor:** To assist with debugging, you can now resize the dynamic arrow by applying a scale factor to it. The size of the default and rescaled arrows remain consistent even when you change the view scale of the graphics window. Scaling has replaced Vector information that was in previous versions of Analyze Dynamic.

Appearance Enhancements

Dimmed and No Hidden Wireframe View

Dimmed and No Hidden Wireframe views now support solids, surfaces, and STL parts as shown in the following examples.

Dimmed Wireframe (Surfaces)

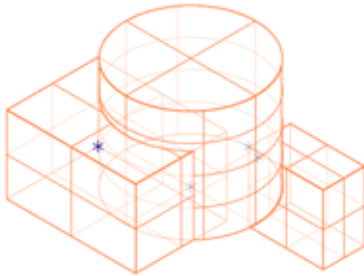

Dimmed Wireframe (Solids)

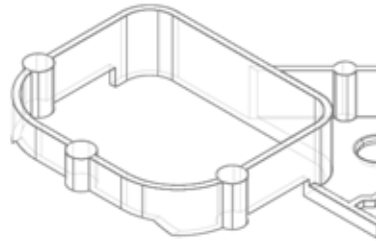

No Hidden Wireframe (Surfaces)



No Hidden Wireframe (Solids)

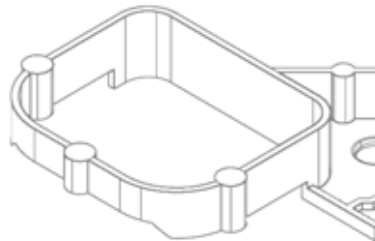

Outline Shaded Support for Polygon Mesh/STL

The Outline Shaded effect can now be applied to polygon mesh entities, such as STL files, which improves the appearance of details.

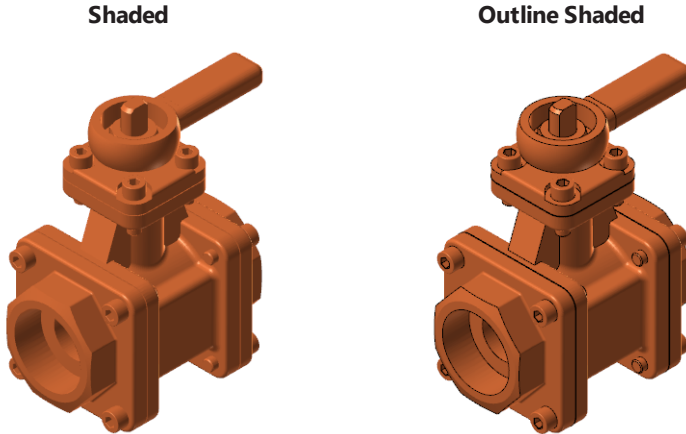

You can also control this affect by using the **Show STL edges** option that has been added to the System Configuration - Shading page. When enabled, STL edges display in the Outline Shaded view; when the option is disabled, STL edges do not display. This option is enabled by default.

The **Edge angle tolerance** option becomes available when the Show STL edges option is enabled. This value determines what is considered an edge on the STL entity.



Rendered Modes

You can now view your solid and surface models as if they were **Metallic**, **Plastic**, or **Glossy**. Select one of these options on the **View** tab to change your part's appearance.

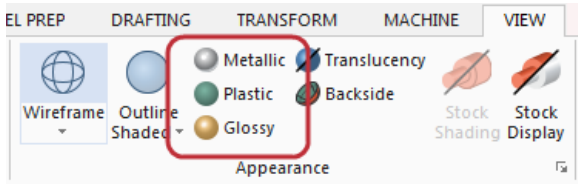

Default

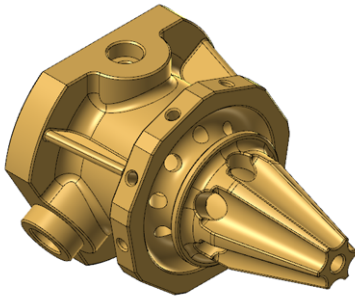

Metallic

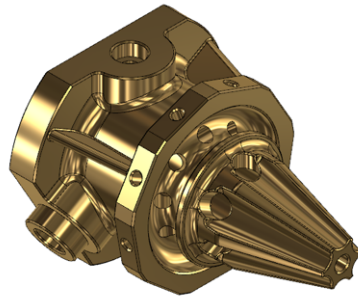

Plastic

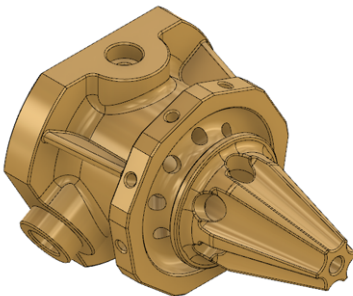

Glossy

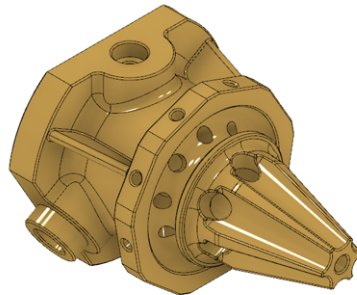

Solid Edges in No Hidden Wireframe Mode

In previous Mastercam versions, you could select hidden edges when in No Hidden Wireframe view mode.

In Mastercam 2017, you can no longer select hidden edges when in this mode. When working in **Translucent** mode, the edges will show and will be selectable.

ATP Enhancements

Chain Sorting

You can now sort chains based on their area, length, or creation order. You can then sort them by either **Ascending** or **Descending** order.

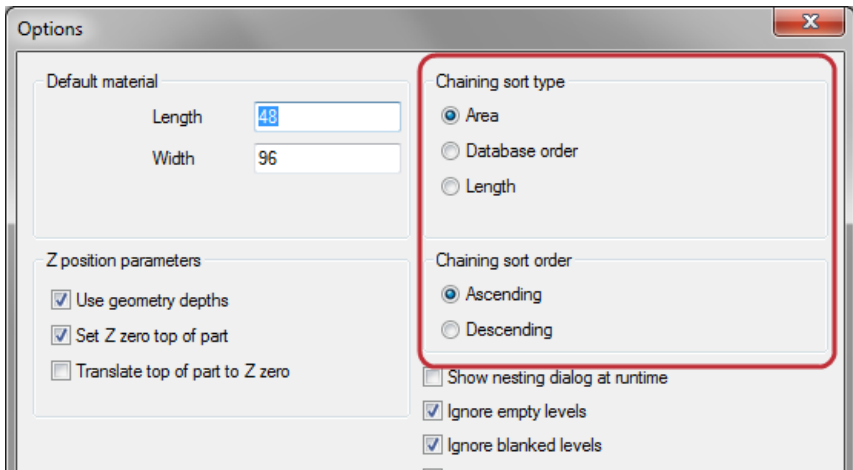

Z Position

Use the **Translate top of part to Z zero** option to move the top of the geometry to $Z = 0$.

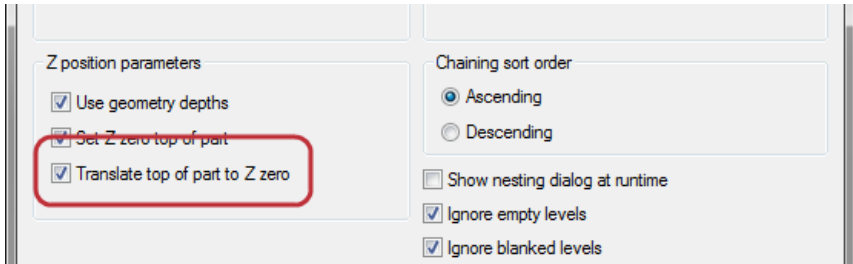

Automatic Support for GDT Data

Unigraphics/NX and STEP Files

Mastercam 2017 now supports saved views and 3D annotation data in imported Unigraphics/NX and STEP files. You no longer need to select the **Import GDT data** option to import annotated data from Unigraphics files. Mastercam automatically imports any saved views into Mastercam named planes.

CATIA Version 5

Support for saved views and annotation data requires the CATIA Version 5 translator with PMI license.

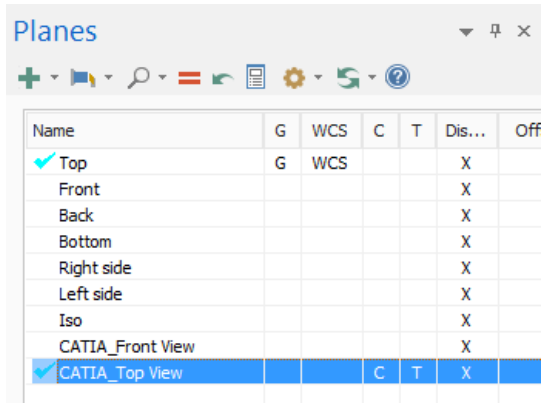

The screenshot shows the 'Planes' dialog box in CATIA. It features a toolbar with icons for adding, deleting, and refreshing views, as well as search and help functions. Below the toolbar is a table with columns for Name, G, WCS, C, T, Dis..., and Off. The 'CATIA_Top View' row is highlighted in blue and has checkmarks in the G, C, T, and Dis... columns.

Name	G	WCS	C	T	Dis...	Off
<input checked="" type="checkbox"/> Top	G	WCS			X	
Front					X	
Back					X	
Bottom					X	
Right side					X	
Left side					X	
Iso					X	
CATIA_Front View					X	
<input checked="" type="checkbox"/> CATIA_Top View			C	T	X	

Code Expert Enhancements

Individual Fonts and Colors in NC Configuration

Fonts and colors can now be set for individual components within your NC Configuration.

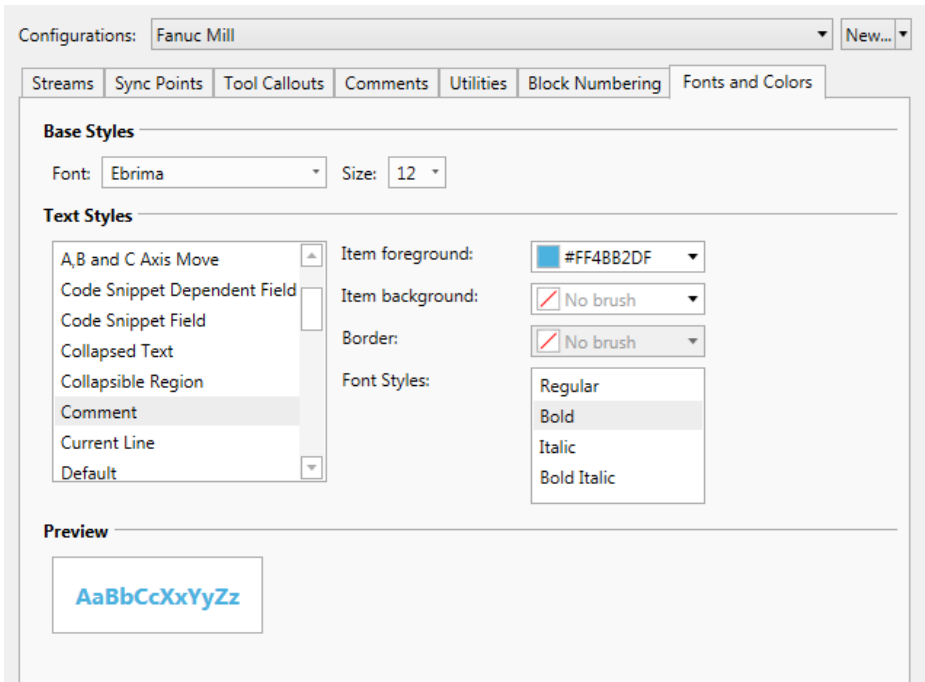

Right-click and select the NC Configuration to apply it to a specific NC file. The Comments are now blue and bold as shown below.

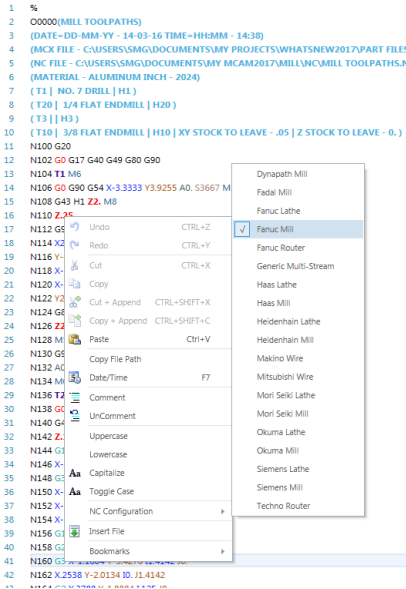

Tool Change Indicator

The **Mark** option has been added to the Tools group of the **NC Functions** tab when an NC file is open in Code Expert.

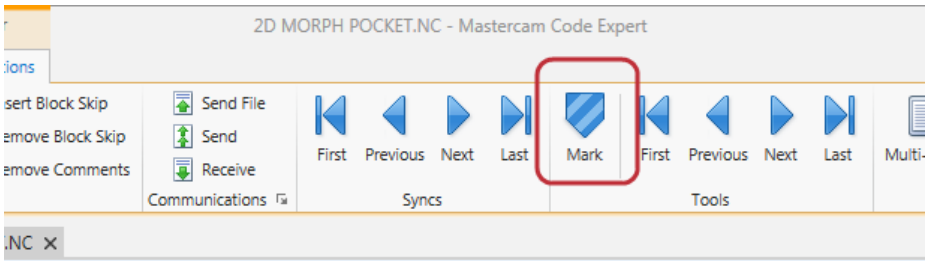

Select this option to add an indicator to the margin of the NC file where tool changes appear as defined in the NC Configuration.

```
256 X14.165 Z-72.667
257 G0 X20.5
258 G28 U0. V0. W0. M05
▶ 259 T0300
260 M01
261 (TOOL - 2 OFFSET - 2)
262 (OD FINISH RIGHT - 35 DEG. INSERT - VNMG 16 04 08)
▶ 263 ( OD - FINISH WITH PLUNGE )
264 G0 T0202
265 G18
266 G97 S3600 M03
267 G0 G54 X18.86 Z-54.951
268 G50 S3600
```

Character Encoding to Opened and Saved Text Based Files

Non-English Mastercam users can now set default encoding to use in Code Expert when opening text files:

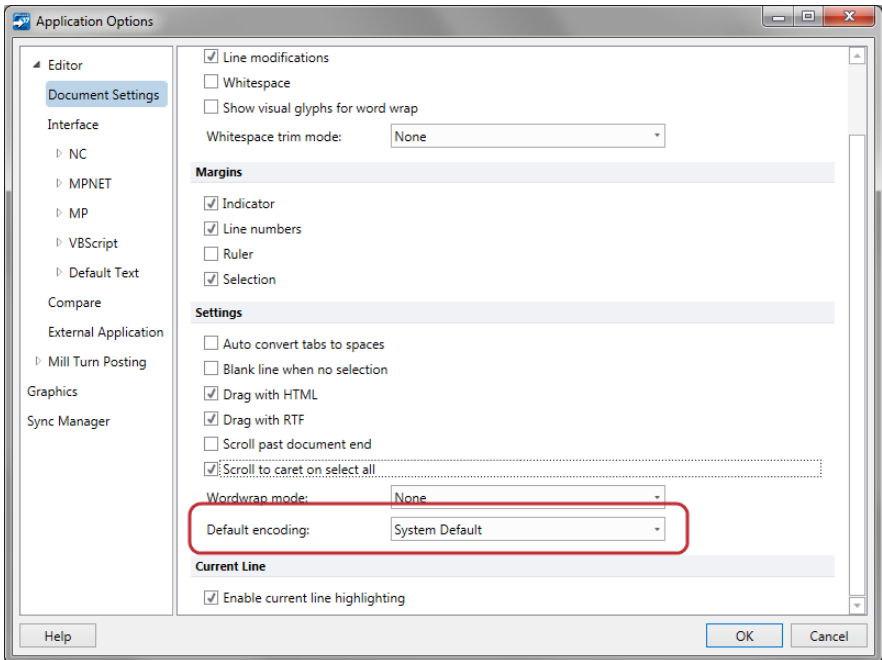

A new option has also been added to the **Home** tab, allowing you to reopen the current file using a specified encoding.

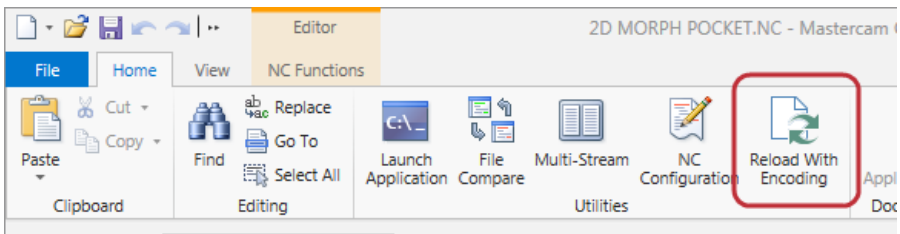

By clicking **Reload With Encoding**, the Select Character Encoding dialog displays, and you can choose a different character encoding.

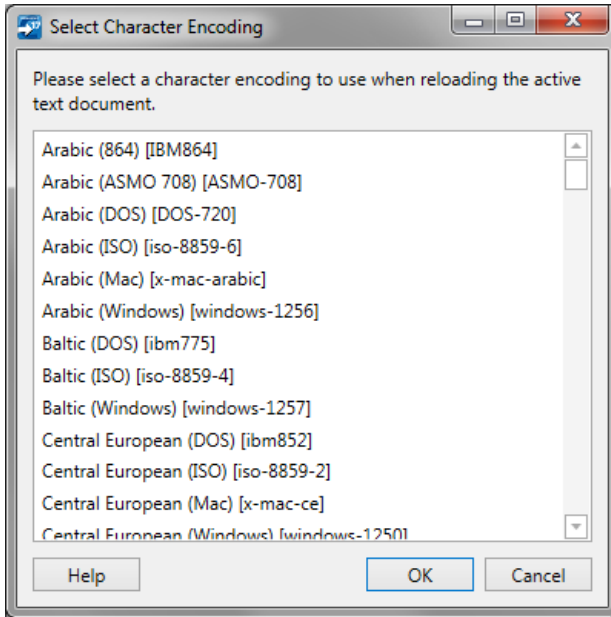

Character Encoding also allows for proper character display:

Mastercam X9

```

1  %
2  O0000(ENCODINGX9)
3  (DATE=DD-MM-YY - 14-03-16 TIME=HH:MM - 14:30)
4  (MCX FILE - C:\USERS\SMG\DOCUMENTS\MY PROJECTS\WHAT'SNEW2017\PART FILES\*****.MCX-9)
5  (NC FILE - C:\USERS\SMG\DOCUMENTS\MY PROJECTS\WHAT'SNEW2017\PART FILES\ENCODINGX9.NC)
6  (MATERIAL - ALUMINUM INCH - 2024)
7  ( T239 | 1/2 FLAT ENDMILL | H239 )
8  N100 G20
9  N110 G0 G17 G40 G49 G80 G90
10 N120 T239 M6
    
```

Mastercam 2017

```
1 |
2 O0000(ENCODING2017)
3 (DATE=DD-MM-YY - 14-03-16 TIME=HH:MM - 14:29)
4 (MCX FILE - C:\USERS\SMG\DOCUMENTS\MY PROJECTS\WHATSNEW2017\PART FILES\花.....待棉身航插.MCAM)
5 (NC FILE - C:\USERS\SMG\DOCUMENTS\MY PROJECTS\WHATSNEW2017\PART FILES\ENCODING2017.NC)
6 (MATERIAL - ALUMINUM INCH - 2024)
7 ( T239 | 1/2 FLAT ENDMILL | H239 )
8 N100 G20
9 N110 G0 G17 G40 G49 G80 G90
10 N120 T239 M6
```

Improve Communications Options for CIMCO

In previous versions, users that communicate with their machines via CIMCO DNC through Code Expert were forced to set communications settings in the System Configurations dialog box. In Mastercam 2017, this process has been simplified by allowing access to the CIMCO DNC settings directly from the Code Expert interface. The settings are easily accessible by clicking the dialog box launcher in the **Communications** group in the **NC Functions** tab.

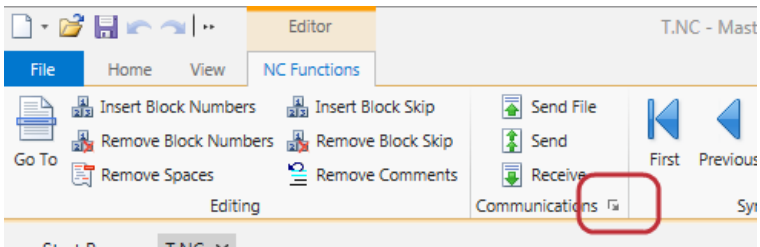

General Toolpath Enhancements

Drag and Drop Operations Import

You can now drag and drop operation files directly into the Toolpaths Manager. When a supported operations file is dropped onto the Toolpaths Manager, the Import Toolpath Operations dialog box displays. The dropped file is automatically set as the source library.

Drill Point Selection

Previously, Drill Point Selection only supported wireframe entities. Now, Drill Point Selection recognizes solid edges when you select the **Entities** option.

Ghosted Operations Support

Stock Model operations can now process ghosted operations. Select **Process ghosted operations** on the Source Operations page of a Stock Model operation to process them. Deselect this option to ignore ghosted operations.

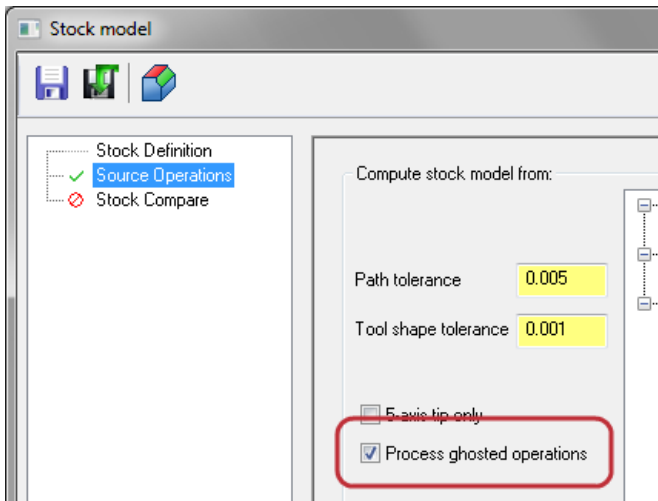

This option is useful when using Multiaxis Link or transform operations.

Reverse Chains Order

You can now reverse the order of chains in the Chain Manager dialog box by selecting **Reverse chains order** from the right-click menu.

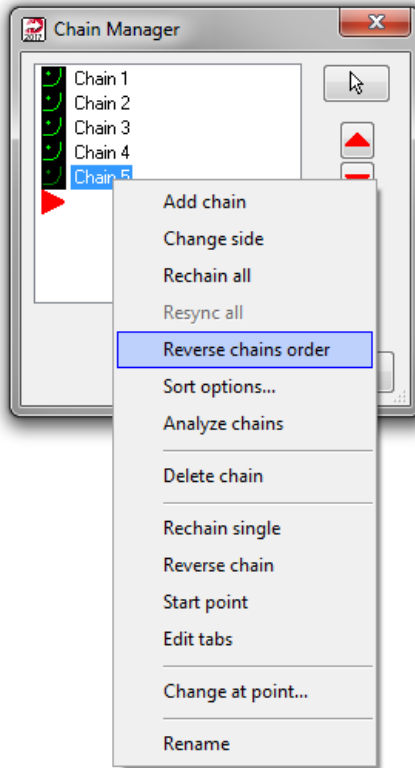

Preventing Changes to Processing Toolpaths

In previous versions, you were allowed to make changes to a toolpath operation while it was still processing in the Multi-Threading Manager. This could cause changes not to stick once the processing was finished.

In Mastercam 2017, a warning displays when you attempt to change the parameters, tool(s), geometry, or NCI while an operation is processing.

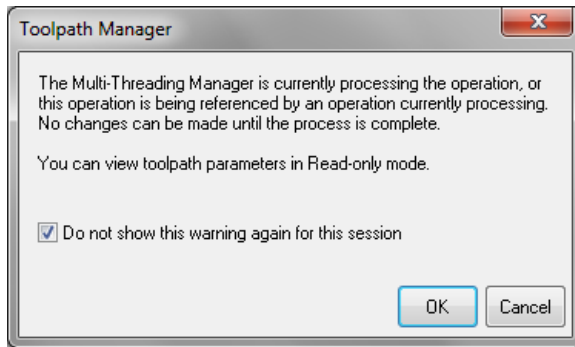

You can still view the parameters or geometry, but the toolpath dialog box will be Read-only.

Toolpath Transform Enhancements

Include WCS

Plane names for Mirror, Rotate, and Translate transform types have been improved. When creating a transform toolpath by **Tool plane**, you can now include the WCS by selecting **Include WCS** in the Type and Methods tab of the Transform Operation Parameters dialog box.

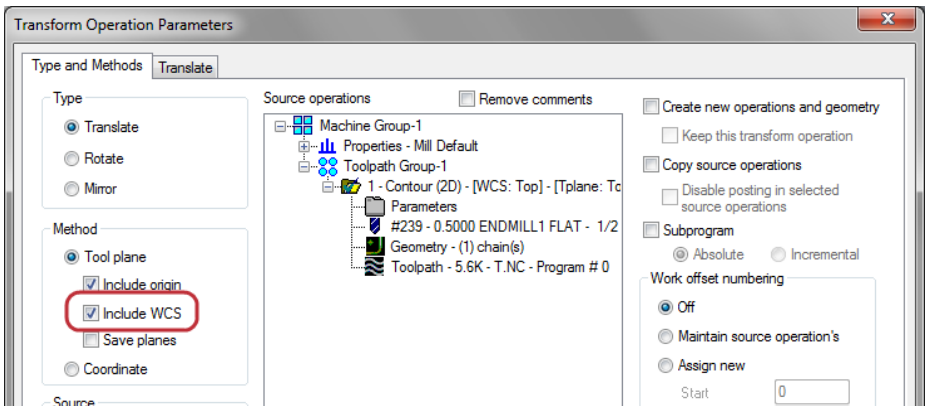

Swap Lead in/Lead out Values

When creating a Mirror transform operation, use the **Swap lead in/out parameters** option to swap the lead-in and lead-out values for the resulting toolpaths.

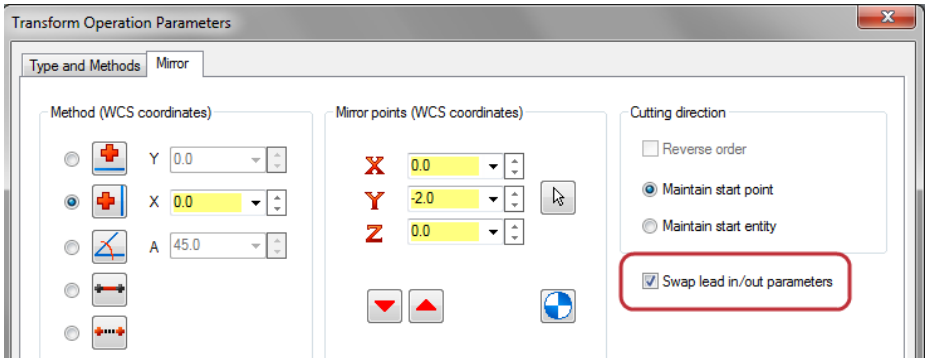

Graphics Window Enhancements

Axes Display Enhancements

Screen Info Renamed and Enhanced

Screen Info [F9] has been renamed to Show Axes. The **Show Axes** function located on the **View** tab controls the display of World, WCS, Tplane, and Cplane axes separately.

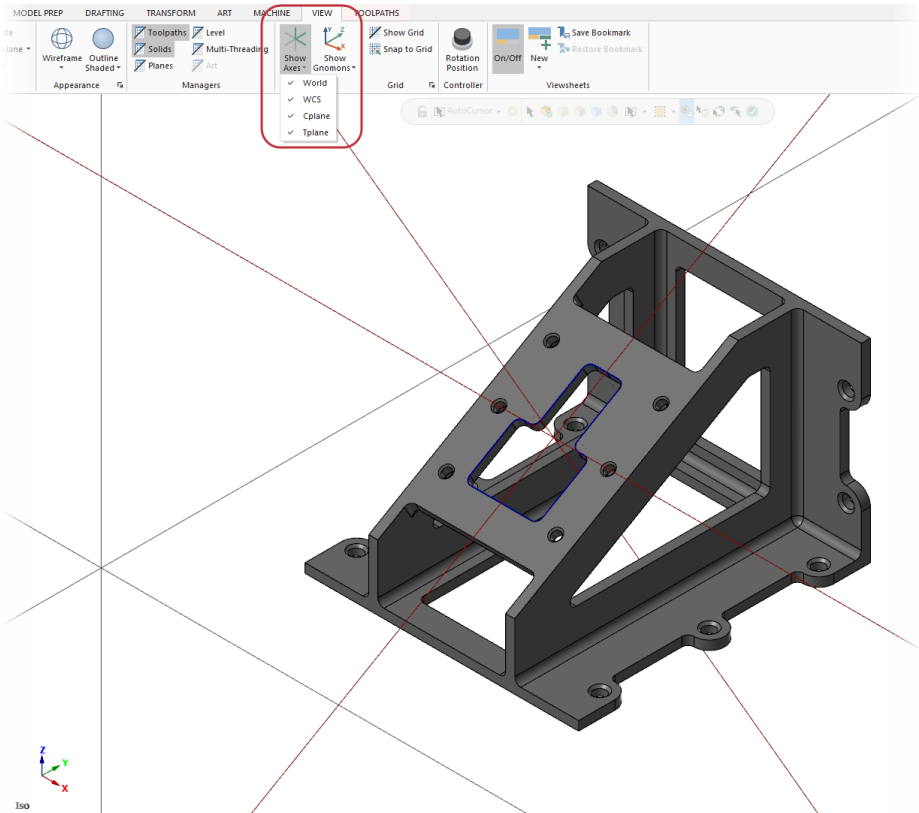

WCS T/Cplane Axes Renamed and Enhanced

The WCS T/Cplane axes [**Alt+F9**] command has been renamed to Show Gnomons. The **Show Gnomons** function located on the **View** tab controls the display of WCS, Tplane, and Cplane gnomons separately.

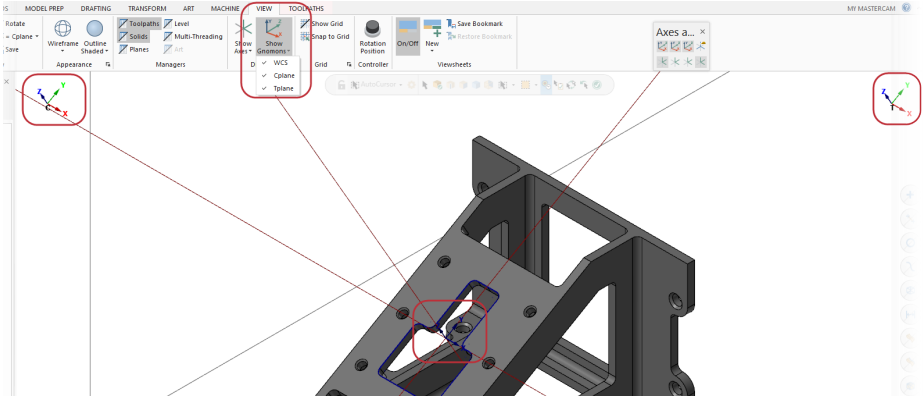

Interactive Gview Gnomon for Dynamic Planes

Dynamic plane creation can now be triggered by clicking the Gview gnomon as shown in the following sequence of illustrations. Move the mouse over the static Gview gnomon until it highlights. Click the origin ball to attach the mouse cursor and drag your cursor to initiate dynamic plane creation.

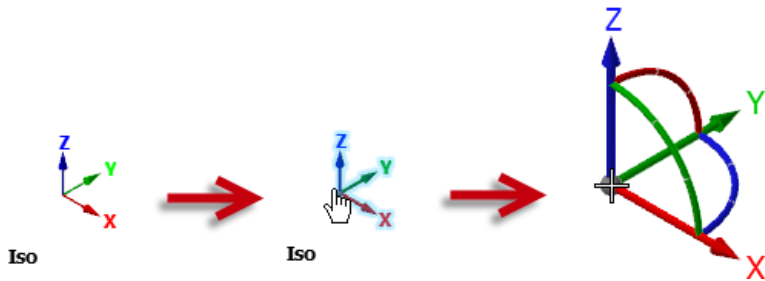

Updated Grid Functions

The grid functions, Active Grid and Visible Grid, previously located on the Grid Settings dialog box have been renamed to **Snap to Grid** and **Show Grid**. These functions are now available on the **View** tab.

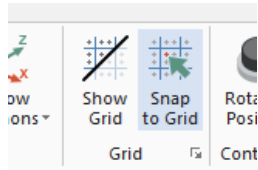

Levels Manager Enhancements

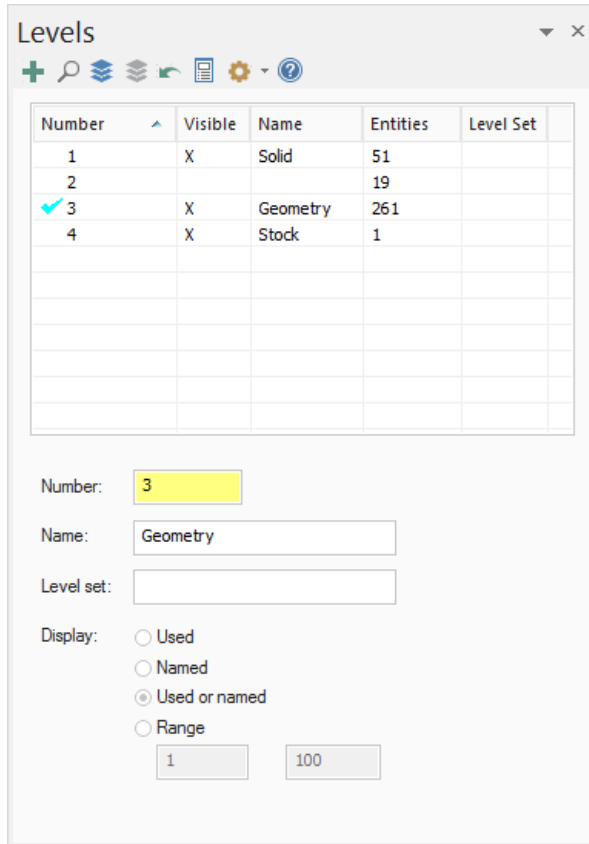

The Levels Manager is now a dockable, floatable function panel and has been redesigned for more intuitive controls and easier workflow. The toolbar across the top of the Levels Manager includes the following functionality:

- Add a New Level
- Find a Level from Geometry

- Turn All Levels On/Off
- Reset All Levels
- Display Options
- Hide properties

Column Reordering

You can reorder the columns in the Levels Manager by dragging the column heading. Column order is maintained from session to session.

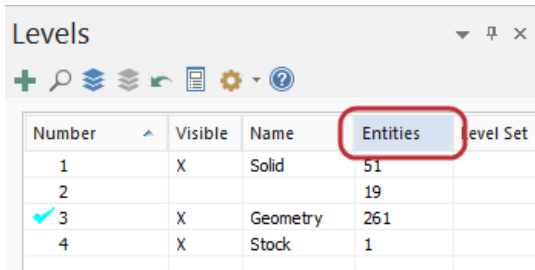

The screenshot shows the 'Levels' window with a toolbar and a table. The 'Entities' column header is circled in red.

Number	Visible	Name	Entities	Level Set
1	X	Solid	51	
2			19	
✓ 3	X	Geometry	261	
4	X	Stock	1	

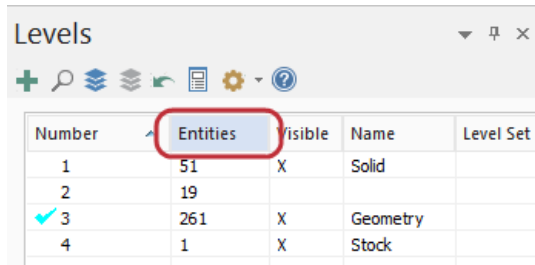

The screenshot shows the 'Levels' window after the 'Entities' column has been repositioned to the second column. The 'Entities' column header is circled in red.

Number	Entities	Visible	Name	Level Set
1	51	X	Solid	
2	19			
✓ 3	261	X	Geometry	
4	1	X	Stock	

Hide or Display Columns

You can hide columns in the Levels Manager by right-clicking a column header and selecting a column. The Number column is always displayed.

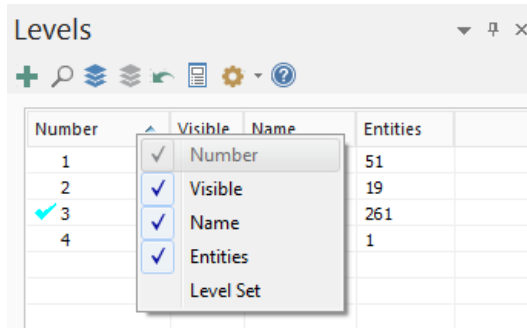

Hide Level Properties

You can now hide the controls below the grid, such as **Number**, **Name**, and **Level set**. Use this control to maximize the space allotted to the grid, minimize the space used by the managers, or to stack the Levels and Planes Managers on top of one another. Click the button again to show the controls.

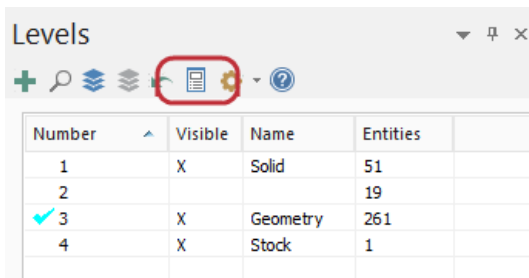

Mastercam Add-On Enhancements

STL Heal C-Hook

You can now enter a negative offset distance (and apply an inward offset), instead of only a positive offset distance.

Support for OnShape Documents

Mastercam has partnered with Onshape; a new, full-cloud 3D CAD system, and has developed **Onshape Connect**. Running from within Mastercam, Onshape Connect allows you to download Onshape elements from the cloud to your local or network drive. Supported file types, including Onshape Part Studios, can be imported directly into Mastercam.

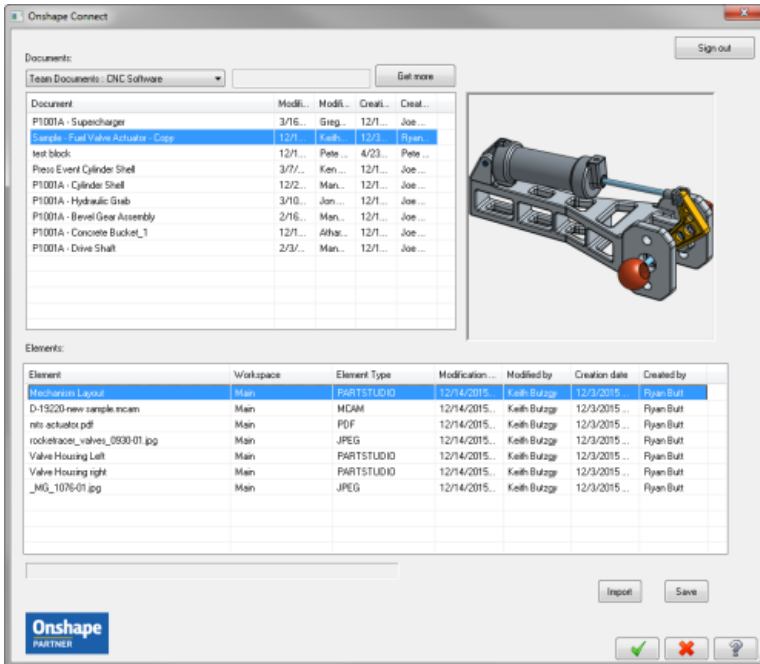

Note: Onshape Connect is available from the Onshape App Store (<https://appstore.onshape.com>). You must have an Onshape account to use Onshape Connect. For more information, please visit www.onshape.com.

Mastercam File Extensions

For Mastercam 2017, the following file extensions have been changed:

Mastercam X9	Mastercam 2017
.mcx-9	.mcam
.emcx-9	.emcam
.operations-9	.mcam-operations
.defaults-9	.mcam-defaults
.mmd-9	.mcam-mmd
.lmd-9	.mcam-lmd
.rmd-9	.mcam-rmd
.wmd-9	.mcam-wmd
.gmd-9	.mcam-gmd
.control-9	.mcam-control
.materials-9	.mcam-materials

Mastercam Simulator Enhancements

Auto Start

The **Enable Auto Start** option has been added to the Options dialog box on the General page for Mastercam Simulator. When selected, Mastercam Simulator will immediately begin to play once a sufficient amount of data has been transferred.

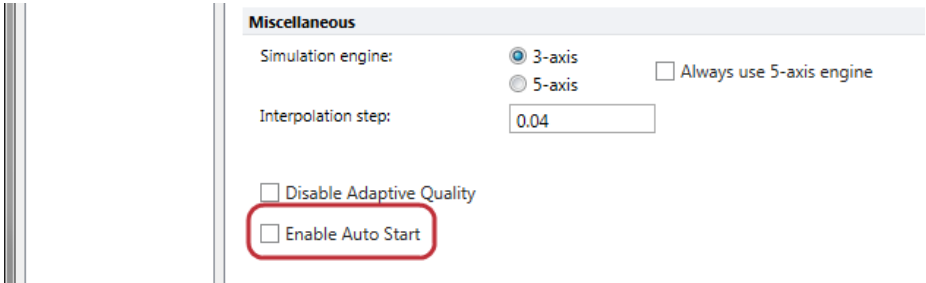

Fixture Support Enhancements

Fixture support, which was previously added with Mastercam X9, has been improved. You can now select a solid, multiple levels, or browse for a file to be used as a fixture.

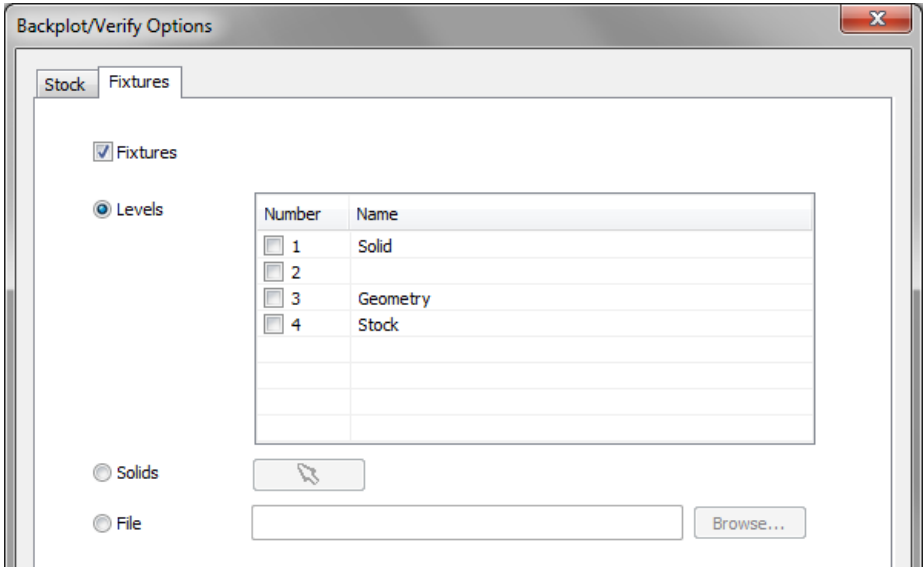

Printing

You can now directly print from Mastercam Simulator by selecting **File, Print**. You will print the current active window view, which is displayed with a red border.

Record Video

You can now save a video of a backplot or verification session from Mastercam Simulator in a common format (.mp4) that can be viewed by anyone with or without Mastercam on their machines.

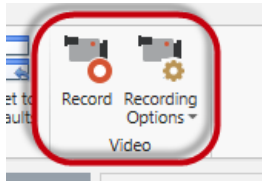

Click **Record** in the **Home** tab to begin recording a video. Once you have finished, click **Record** again to stop recording. You then save the recording and you can distribute as needed.

Reverse Direction for Clipping Planes

You can now reverse the direction of clipping planes when using them in Mastercam Simulator.

Synchronize Views

You can now link your view in Mastercam to your view in Mastercam Simulator so if you rotate your part in one, the other will update. You can turn this option on or off in the **View** tab of Mastercam Simulator.

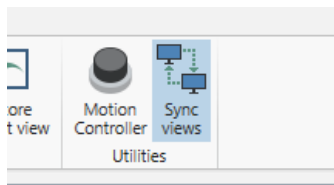

Printing Multiple Copies

You can now print multiple copies using the **Copies** option, located on the **File, Print** page.

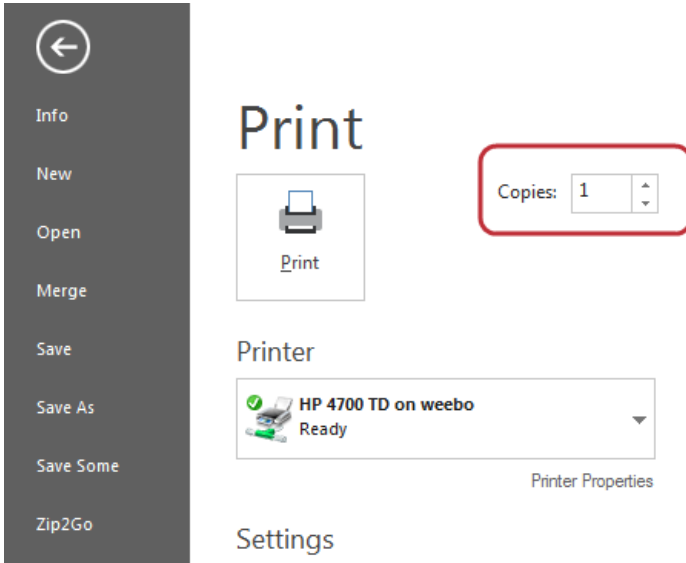

Migration of Custom Machine Simulation Files

The Migration Wizard now supports the migration of custom machine simulation files. The **Machine simulation** option has been added to the wizard and includes the STL, GIF, and BMP files that create the machine model.

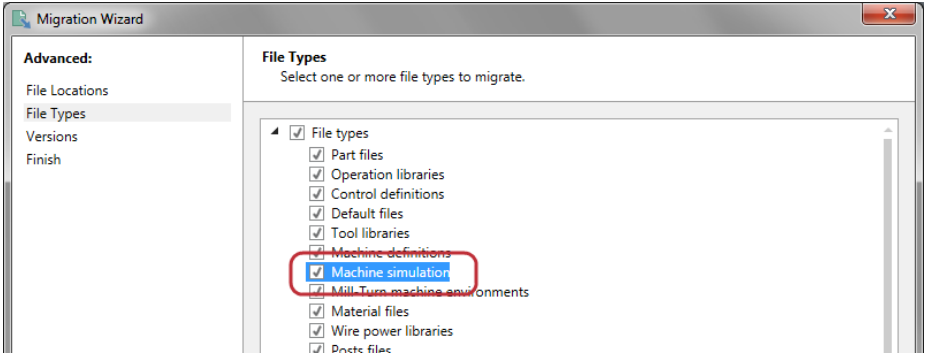

Multiple Instances Now Supported

When opening an additional instance of Mastercam, you no longer get the warning shown below. You can now open additional instances of Mastercam without instability or data loss.

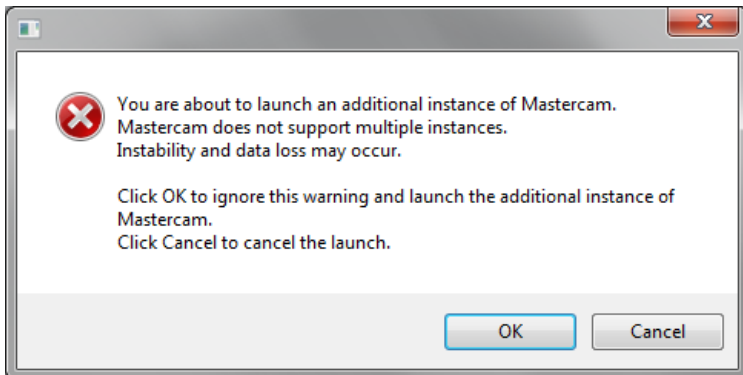

Planes Manager Enhancements

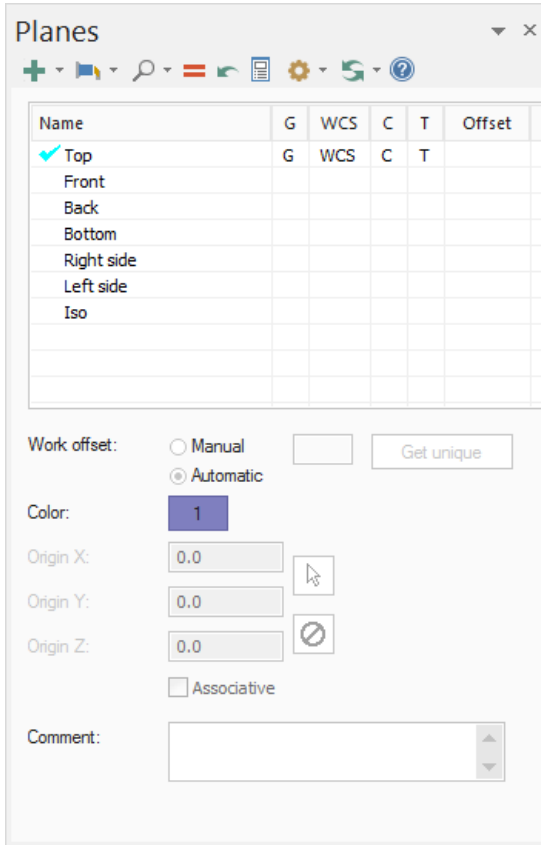

The Planes Manager is now a dockable, floatable function panel and has been redesigned for more intuitive controls and easier workflow. The toolbar across the top of the Planes Manager includes the following functionality:

- Create a new plane (from Geometry, Solid Face, Gview, Line Normal, Relative to WCS, and Dynamic)
- Select a lathe plane (radius X/Z or diameter/Z coordinates)

- Find a plane (From Geometry, Plane, or Relative to WCS)
- Set/Reset your current WCS, construction plane, and tool plane with origins
- Display Options
- Follow rules
- Hide properties

Always Display Gnomon

In previous versions of Mastercam, the gnomon for the active plane was only displayed when the Planes Manager had focus. Now, you can set the gnomon for the active plane to always display.

Hide or Display Columns

You can hide or display columns in the Planes Manager by right-clicking a column header and selecting a column.

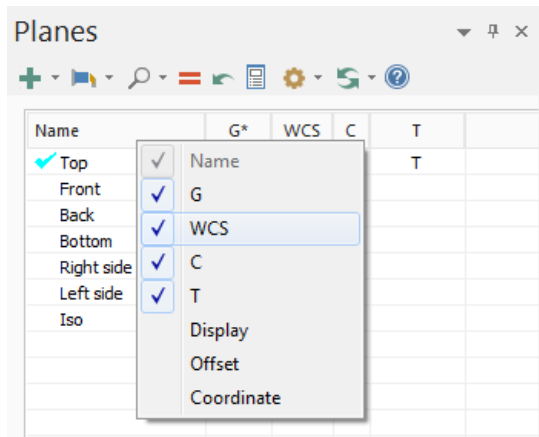

Hide Planes Properties

You can now hide the controls below the grid, such as **Work offset**, **Color**, and **Comment**. Use this control to maximize the space allotted to the grid, minimize the space used by the managers, or to stack the Levels and Planes Managers on top of one another. Click the button again to show the controls.

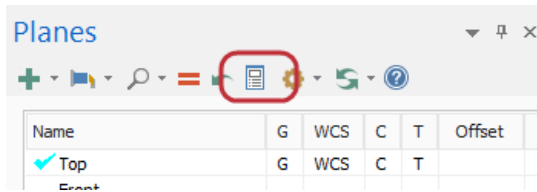

New G Column to Set Gview in Planes Manager

A column has been added to the Planes Manager. Click in the **G** column to change the Gview to that plane.

New Follow Rule

A follow rule has been added, **Tplane follows Cplane**. The follow rule is selected by default, but the state persists from session to session. With this follow rule selected, the Tplane will change if the Cplane is changed by the user or as a result of another follow rule, such as **Cplane follows Gview**. The Tplane can still be changed independently from the Cplane.

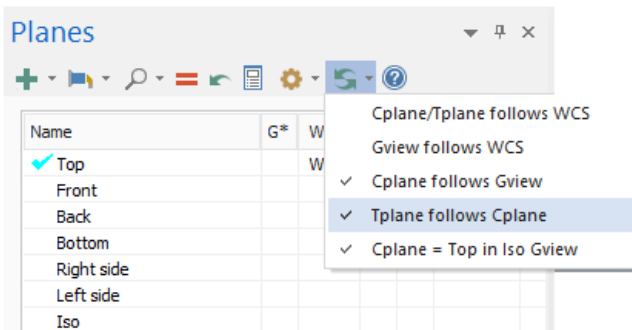

Origin Enhancements

Previously, the Planes Manager displayed origin values in view coordinates. Now, the origin values display in world coordinates. The origin values also display in the Planes (WCS) page of tree-style toolpaths and the Plane Selection dialog box.

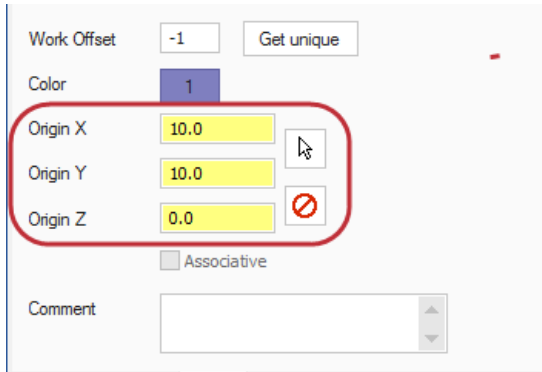

The Origin fields will also display a simplified right-click menu that is more appropriate for picking plane origin XYZ points. This applies to any parameter where you use the right-click menu to set origin values.

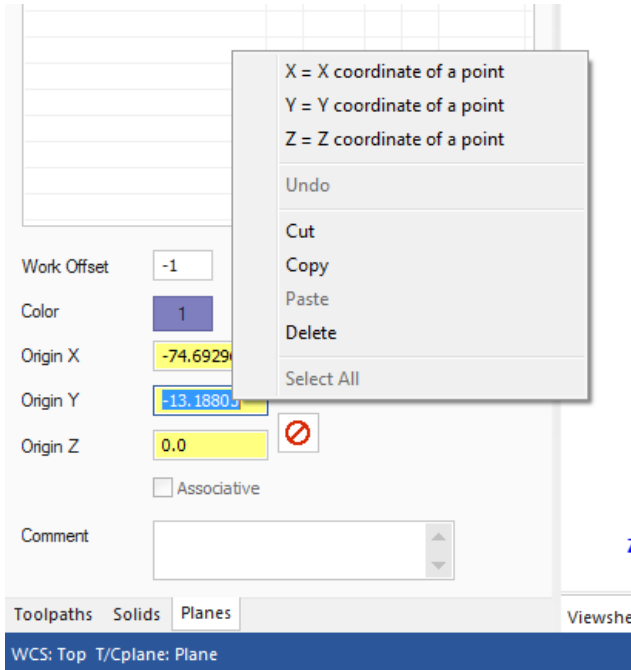

Reorder Columns

You can now reorder columns in the Planes Manager by dragging and dropping the column headers. Column order is maintained from session to session.

Recent Functions

The Most Recently Used functions toolbar has been renamed to Recent Functions and is now a dockable, floatable function panel. Recent Functions allows you to see a history of the Mastercam functions you recently used and quickly reselect them.

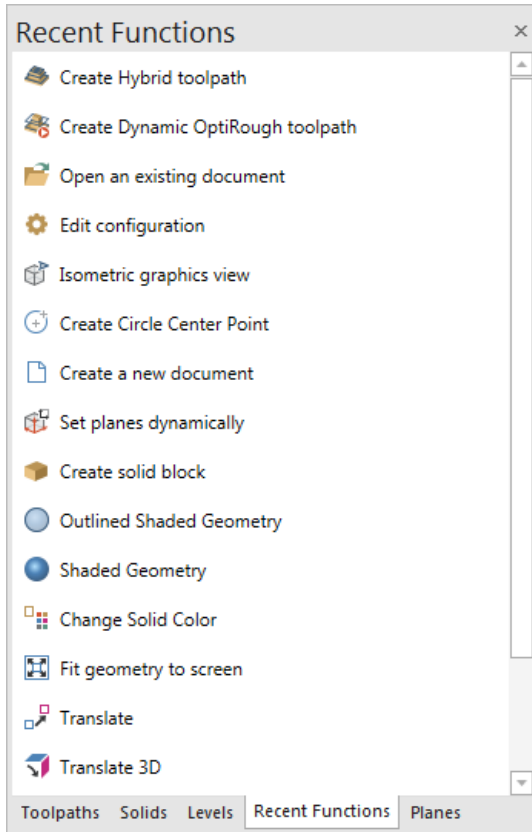

Setup Sheet Enhancements

New Setup Sheet XML Tags

New XML tags have been added to the setup sheet, such as tool and holder location, machine type, machine name, and post processor file name.

Option to Clean Up XML Folder

An option has been added that deletes all XMP and BMP files automatically created at run time during your previous setup sheet sessions. Use this to help you maintain disk space.

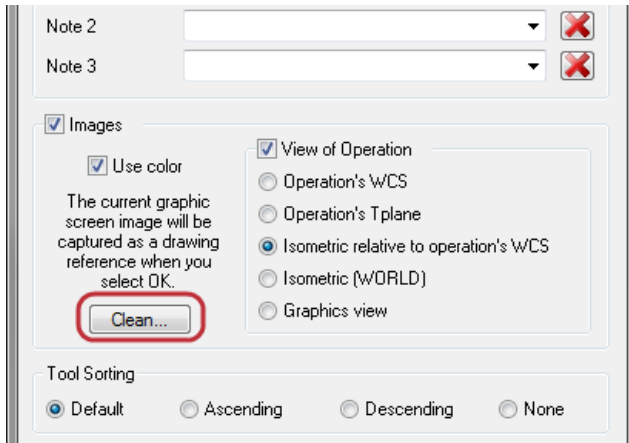

After you click the **Clean** button in the Setup Sheet dialog box, the system informs you of the number of files about to be deleted and prompts you to accept the cleanup or not.

This option is only available if you have previously run the setup sheet function.

Save Images in Nesting Reports

An option has been added to create nesting reports with high resolution images. Select **Higher resolution images in reports** in the Nesting Configuration dialog box to increase the images of sheets and results to a maximum of 2400 pixels and parts to a maximum of 1200 pixels. The orientation determines whether the maximum size will be applied to the length or width.

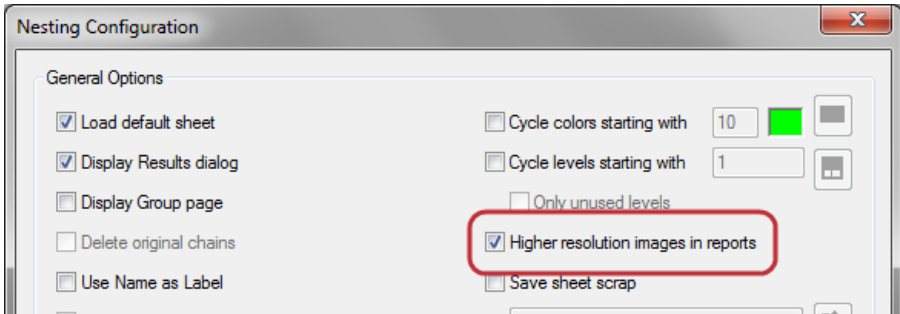

System Configuration Enhancements

Chaining Arrow Size Options

You can now change the size and translucency of 3D chaining arrows to make them more usable when a file has numerous chains in a window (for example, when chaining text for engraving).

If arrows in the graphics window overlap or obscure other arrowheads, you can set the arrow size to **Small**, **Medium**, or **Large**. Change the arrows from opaque to translucent by selecting the **Translucent** checkbox. These options are located on the Chaining page.

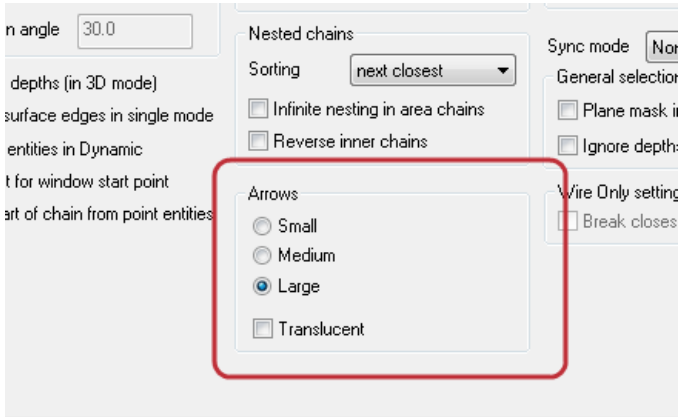

Get Defaults from Previous Operation

The **Get defaults from previous operation** option, located on the Toolpaths page, allows a newly created operation to pull defaults from the previous operation of the same type. If no compatible operation is found, the parameters are pulled from the defaults library. This option is on by default. This functionality was previously delivered via the PrmDef C-Hook, which has been removed from the Mastercam installation.

When disabled, new operation parameters are pulled from the defaults library.

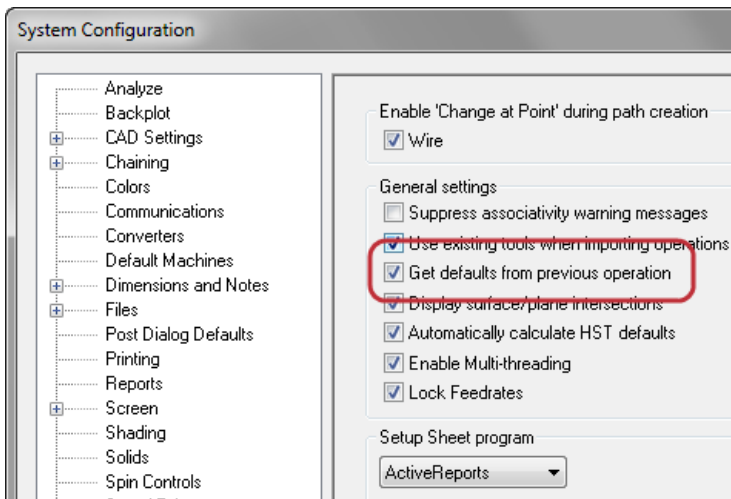

Import Sketch Data from SOLIDWORKS

You now have the ability to import sketch data from a SOLIDWORKS file.

You can automatically include this information by selecting the **Import sketches from SOLIDWORKS files** option located on the Converters page of the System Configuration dialog box.

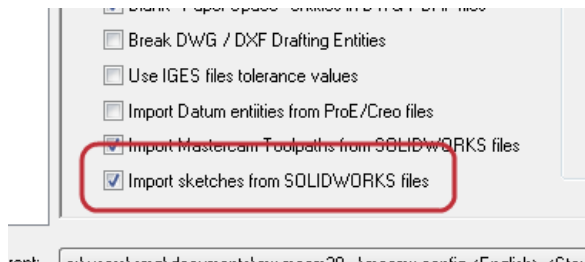

You can also import this information from SOLIDWORKS files as you open them by selecting the **Import Sketches** option from the SOLIDWORKS File Parameters dialog box. The File Parameters dialog box displays when you select the **Options** button on the Open dialog box.

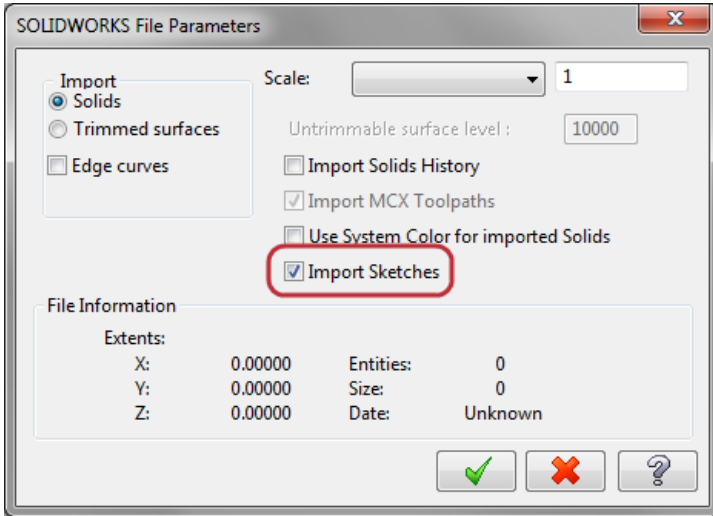

You must have a seat of SOLIDWORKS to import sketch data into Mastercam.

New View Settings Page

The View Settings page, under the Screen page, has been added to the System Configuration dialog box. This page contains options that previously resided on the Screen page.

The **Snap to views in dynamic rotation** setting has been added. Select this option to have your part automatically snap to views during dynamic rotation. The rotated part snaps to a view within the tolerance (in degrees) you set.

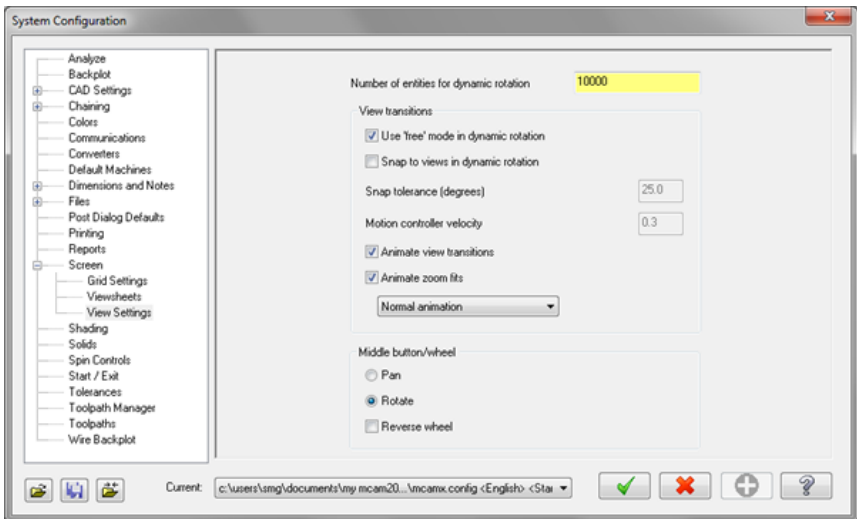

Screen Page Enhancements

The Screen page has been updated as follows:

- The **Display toolpaths** option displays the toolpaths when selected and hides toolpaths when deselected.
- The **Use stipple on solids/surfaces** option displays the stipple overlay effect on auto-highlighted or selected surfaces and removes the stipple overlay effect when deselected.

- The **Display part information** option has been removed in favor of the new Show Axes toggle on the **View** tab.
- The **Display viewport XYZ axes** option has been removed in favor of the new Show Gnomons toggle on the **View** tab.

You can also change the size of gnomons, gnomon labels, on-screen text, and the scale indicator with the **Scale display gnomons and text** option. Use the **Selection controls opacity** slider to adjust the display of the Selection Bar and Quick Mask controls. These options are especially helpful when using a 4K monitor.

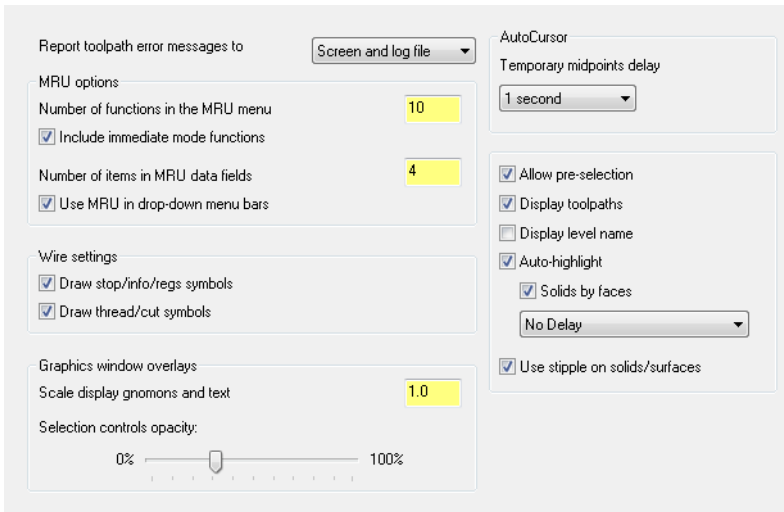

Set Tool Colors

You can now set colors for different sections of a tool on the Colors page. These settings control how the tool displays in the Tool Wizard.

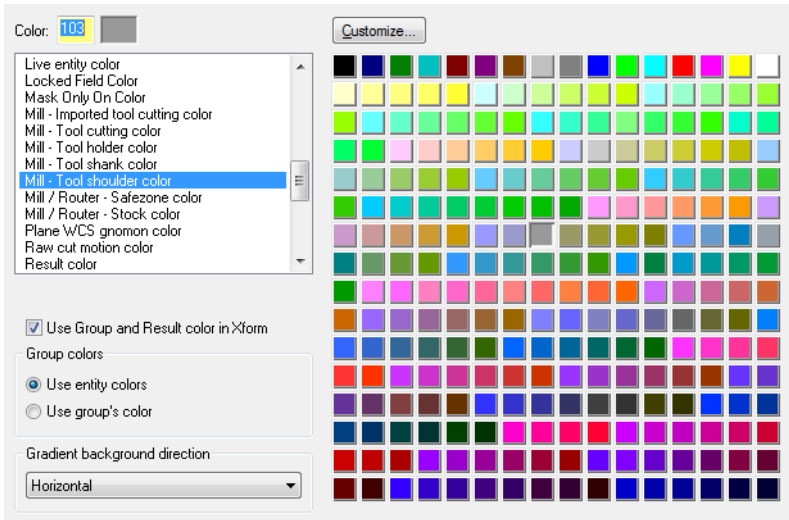

Solid Preview Option

You can now turn the auto-preview off or on for all history-based solids. The **Set solid preview on by default** option is located on the Solids page.

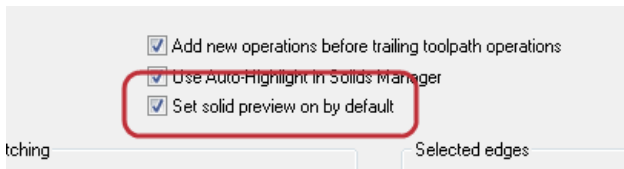

Viewsheet Enhancements

Create and Save Bookmarks from Planes

Two options have been added to the Dynamic Plane and New Plane dialog boxes. Select **Create Viewsheet** to automatically save a viewsheet with the name of the plane upon exiting the dialog box. When **Create Viewsheet** is enabled, the **Save Bookmark** option becomes available, which saves a bookmark on the newly created viewsheet.

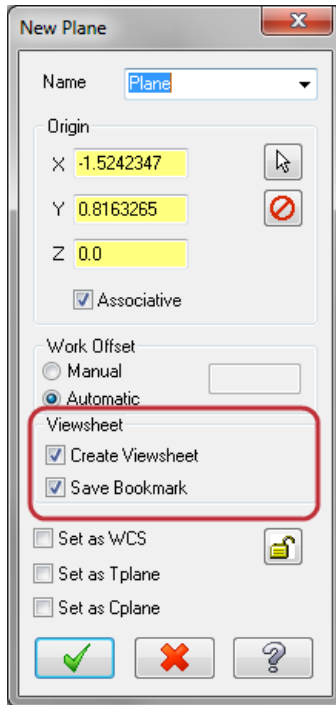

Delete Multiple Viewsheets

You can now select multiple viewsheets and delete them or their bookmarks. To do so, hold down the **[Ctrl]** key while selecting the viewsheets, then right-click and select **Delete Viewsheet** or **Delete Viewsheet Bookmark** from the menu.

Removed the Concept of "Main" Viewsheet

Viewsheets are now less restricted, as there is no longer a "main" viewsheet. You now have the ability to bookmark any viewsheet and reorganize the order of viewsheets as needed.

However, you cannot delete the last remaining viewsheet as there must always be at least one active viewsheet.

Zip2Go Enhancements

The Zip2Go enhancements include the following:

- You can open a Zip2Go (.z2g) file by dragging and dropping the file onto the graphics window.
- The Configure menu selection has been renamed to Options and is found in the **File** menu. Selecting **Options** opens the Options dialog box where you can alter file and folder settings.

DESIGN ENHANCEMENTS

Bounding Box Center Point

In addition to creating a point at the center of the bounding box, the **Center point** option now creates geometry on each flat face of the bounding box. This change only applies to rectangular bounding boxes.

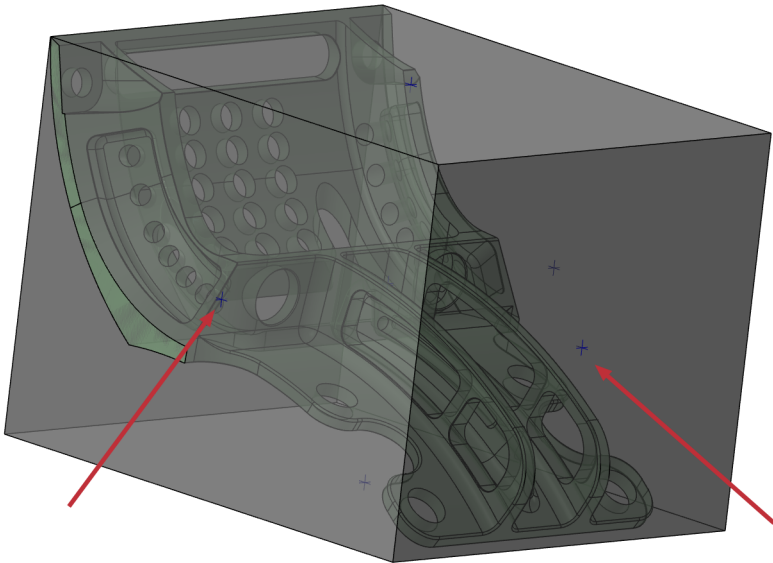

On a cylindrical bounding box, the **Points** option creates a point at the center of two flat faces of the cylinder and the **Center point** option creates a point at the center.

Drafting Enhancements

Drafting formatting

You can now apply the format of an existing dimension to a new dimension by pressing the tilde key [~] and selecting the existing dimension text.

Edit text heights for both notes and dimensions

The **Apply to dimensions and notes** option has been added to the Height dialog box, accessed by selecting **Height** on the Basic tab of the Drafting function panel. This allows you to change both dimension and note heights at the same time.

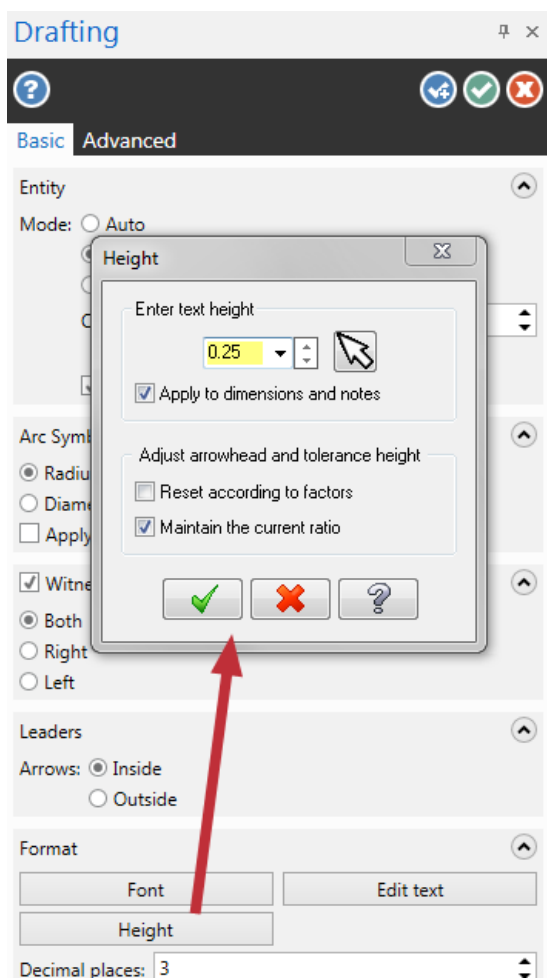

Plane Selection Enhancements

The X, Y, and Z options in the Plane Selection dialog box have been enhanced to increase functionality, accuracy, and efficiency.

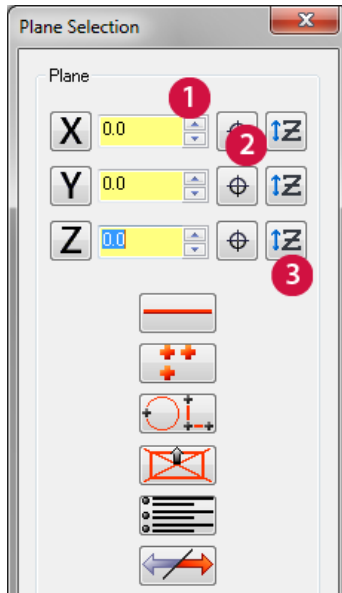

1. Added spin controls.
2. Added **Select point** button. Use this button to select an AutoCursor position from the graphics window. The appropriate X, Y, and Z value of that position will be entered into the corresponding field.
3. Added the **Construction depth** button. Use this button to copy the current Z depth value into the X, Y, or Z fields.

Solids Enhancements

Disassemble Enhancements

The user interface for Disassemble has been improved to better support your designing practices.

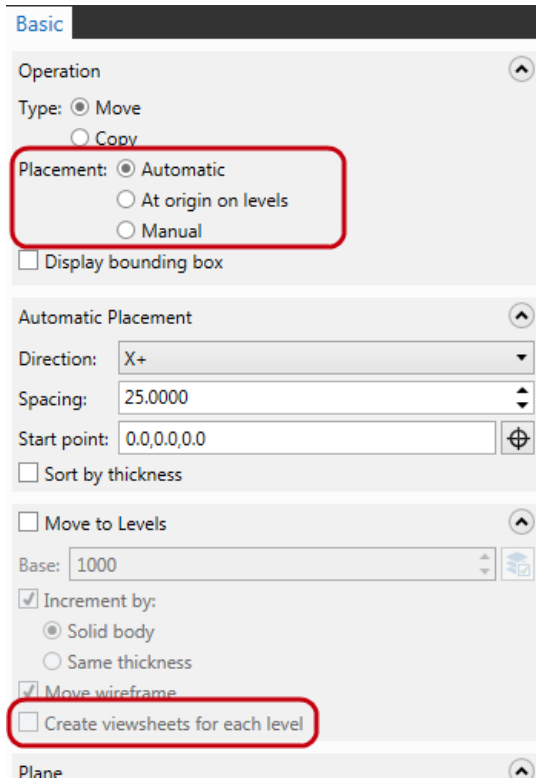

Placement Options

The checkbox for **Automatically place bodies** has been replaced with three radio buttons.

In addition to the **Automatic** and **Manual** options, you can now place dis-assembled bodies at the origin of the Layout level. Bodies placed at the origin through this option can be placed at any level, but the levels can only be incremented by solid bodies and not by thickness.

Undo

Undo is now applied to all solid bodies instead of one solid body at a time.

Viewsheets Support

Select the **Create viewsheets for each level** checkbox to create a viewsheet for bodies on each level. The resulting bodies are moved or copied to a new viewsheet and bookmarked with the new level.

Keep Name After History is Removed

The names of solid bodies are maintained after their history has been removed.

Optimize

Optimize, located under the **Simplify Solid** drop-down in the **Modify** group of the **Model Prep** tab, automatically repairs imported solids (whole bodies or individual faces) by improving the accuracy of edges and by identifying and optimizing blends. Toolpaths on the repaired solid maintain associativity to faces.

Pick Solid Face Color

You can now obtain a color number during the Change Face or Set Feature function by clicking the **Select** button in the Colors dialog box and selecting the solid face.

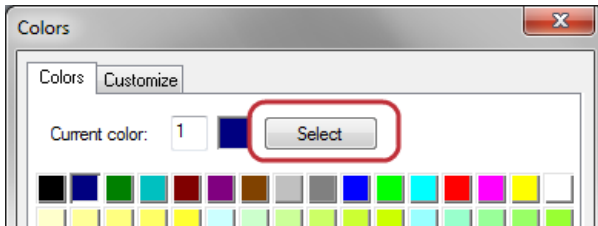

Preprocess Solid

The Surface From Solids function, located on the **Surfaces** tab, now includes a **Preprocess solid** option that can assist in the conversion of solid faces into surfaces.

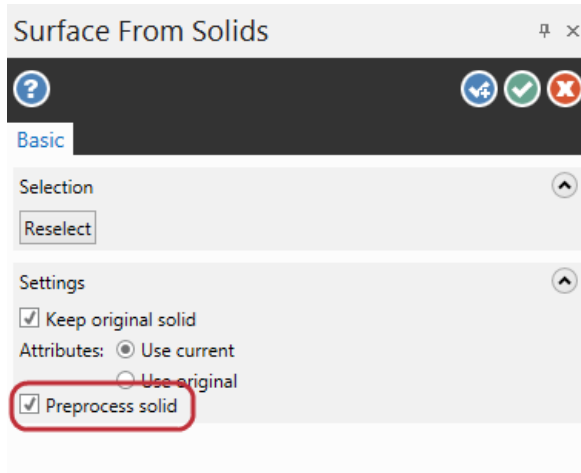

Mastercam makes a copy of the body, prepares it, and then creates surfaces from this body. After the conversion, Mastercam deletes the preprocessed body, leaving the original intact.

Repair Small Faces

Repair Small Faces analyzes solid bodies (with no history) and reports if it finds small entities such as spikes, sliver faces, edge pinches, and gashes. If the function finds these issues, it gives you the option to repair the solid.

Solid Impression

Solid Impression is a function that automates the creation of an electrode tool without having to create an extrusion and Boolean operation. **Solid Impression** produces a negative impression of a selected closed body.

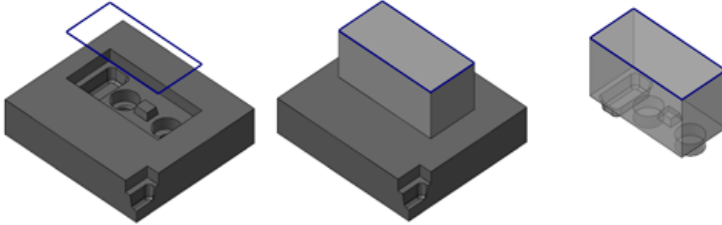

To create the impression, select a planar wireframe chain. The function then projects the chain to the solid body. The depth of the projection is from the wireframe chain to the lowest face of the selected solid or to a selected face.

Transform Enhancements

Transform Dynamic AutoCursor Support

Transform Dynamic now supports AutoCursor snapping to horizontal, vertical, and tangent positions when rotating geometry. These options are only available when the plane equals the Cplane.

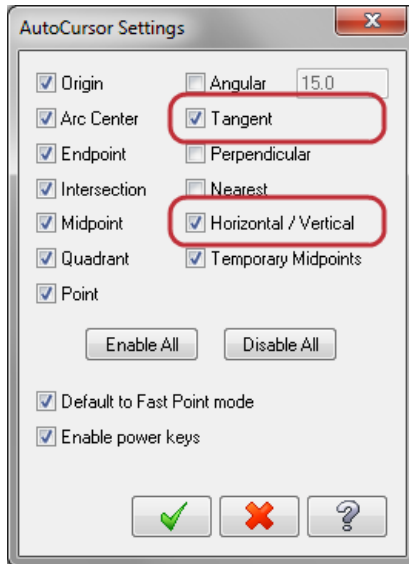

To use these options, select the geometry you wish to transform, then right-click, and select **AutoCursor** to open the AutoCursor Settings dialog box. Select **Tangent** or **Horizontal/Vertical** to activate the snap options.

Rotate the selected geometry, and it will snap horizontal, vertical, or tangent to another entity as shown below.

Snap to tangent

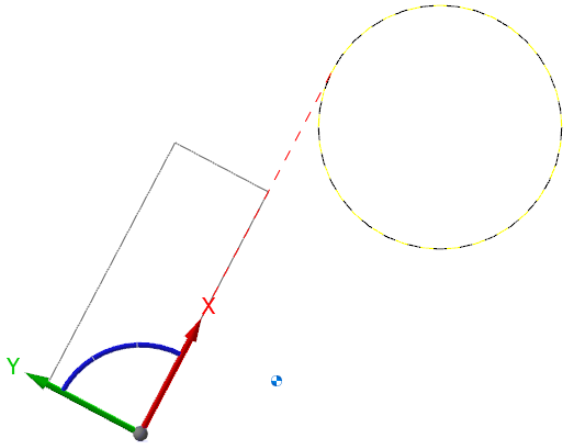

Snap to horizontal

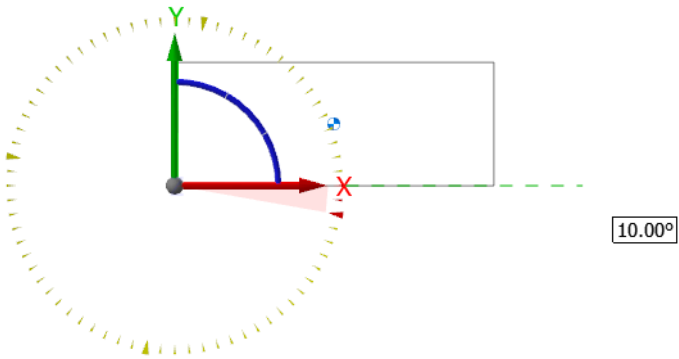

Snap to vertical

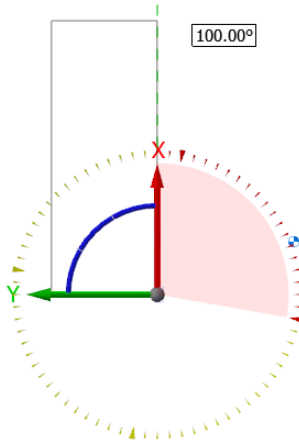

Dynamic Gnomon Editing

The Dynamic Gnomon includes a button that switches between editing the geometry and editing the gnomon positions when using **Translate**.



Gnomon mode



Geometry mode

Translating an entity using the Geometry mode:

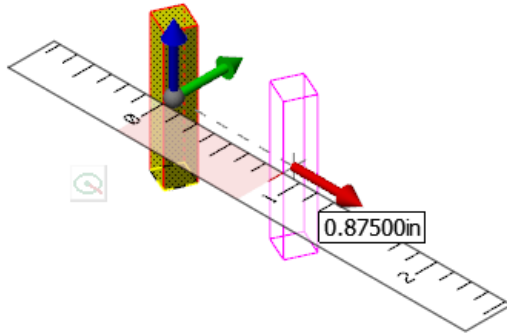

Editing the gnomon position using Gnomon mode:

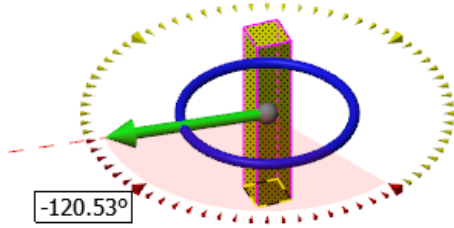

Scale

Scale now includes an **Auto center** option and a scale calculator.

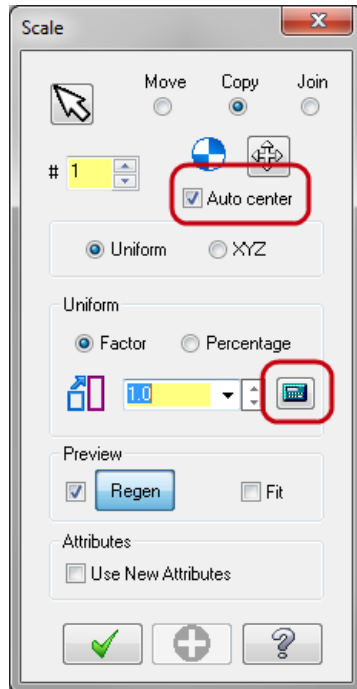

Auto center moves the center of the scaling function to the center of the selected geometry. When the option is deselected, the center of scaling returns to the default (0,0,0).

The Scale Calculator dialog box calculates a scaling factor. You choose a **Base** value and a **Result** value. The calculator then divides the result by the base to get the **Scale factor**.

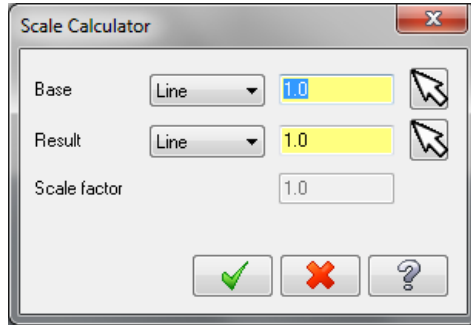

For example, you can enter a **Base** of **3.4** and a **Result** of **5**, it automatically calculates the **Scale factor** of **1.47**. You can also select geometry to define your Base and Result. Select a circle that needs to be scaled to match another circle, and Mastercam will do the calculations for you.

Stretch

You can now dynamically stretch geometry with Mastercam's single-axis arrow control. Window select the entities to transform, then move the individual arrows in the graphics window to stretch along the X, Y, or Z axis.

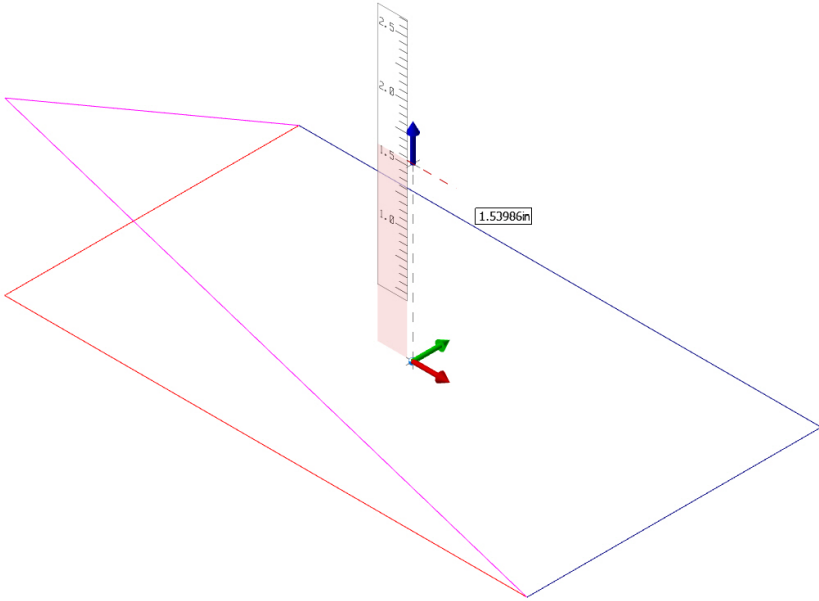

Wireframe Enhancements

User Interface Changes

Most functions that previously used the horizontal ribbon bar have been moved to a function panel for Mastercam 2017. The interface for these functions has the same look and feel as the Solids interface, allowing you to work in the function panel and in the graphics window simultaneously.

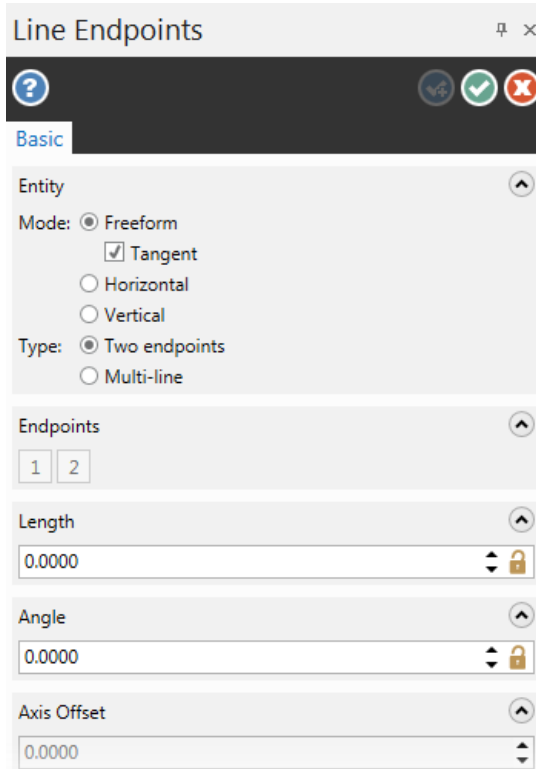

Sharp Corner Smoothing Added to Spline From Curves

The **Sharp Corner Smoothing** option has been added to the Spline From Curves function. Sharp corner smoothing blends in a new spline segment based on the Blend distance.

Break at Points

This function, located on the **Wireframe** tab under **Trim Break Extend**, allows you to break geometry at selected points that lie on it.

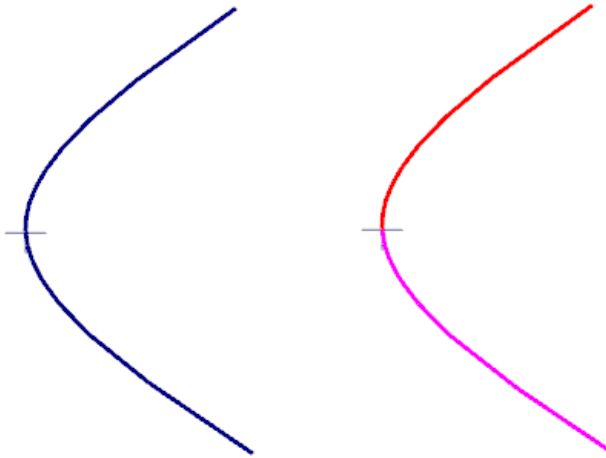

Point and Line Dynamic Split into Two Functions

The Point and Line Dynamic function have been split into two separate functions, Point Dynamic and Line Normal.

Use the **Point Dynamic** function to create points on wireframe entities, surfaces, and solids. Use the **Line Normal** function to create lines perpendicular to any existing surface or solid face.

Refit Spline

Use this function to remake poorly defined splines that have too many nodes or sharp corners at nodes. Refit Spline creates a smoother spline with fewer, more consistently spaced nodes.

Sharp corners are automatically detected and blended for smoother results. You can adjust the corner angle identified for smoothing by changing the value in the **Detection angle** field

Relief Fillet Style

The **Relief** option has been added to the Fillet Entities function. This allows you to put clearance on only one entity. This is useful when the outside faces of the tenon do not hide the current clearance fillet.

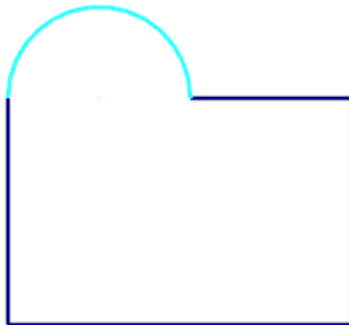

Untrim Spline

Untrim Spline, which was a C-Hook in previous versions of Mastercam, is now a function on the **Wireframe** tab. Use this function to untrim all selected splines and NURBS curves to their original extents. Untrim Spline reverses the effect of earlier trim operations.

Persisting Values for Create Letters

The values that you enter for height and spacing in the Create Letters function will now persist between sessions.

TOOL ENHANCEMENTS

Add and Remove Manufacturers and Tool Grades

You can now add manufacturers and tool grades to a library during tool creation and tool editing from both the Wizard-style dialog boxes and from the property grid in the stand-alone Tool Manager. Click the green plus button next to **Manufacturer name** or **Tool Grade** to add a new name.

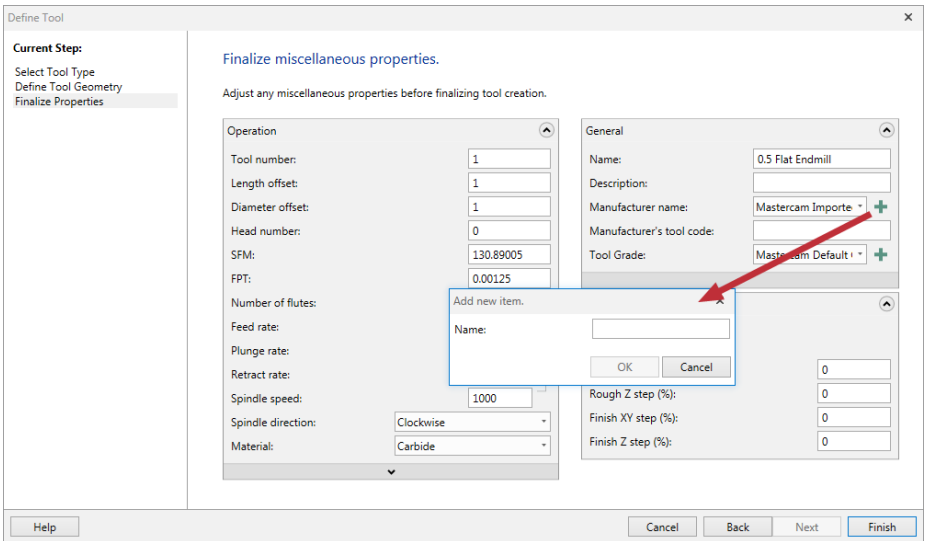

Expand the drop-down lists for **Manufacturer name** and **Tool Grade** to select names that have already been added. Use the buttons to the right of the name to edit or remove it from the list.

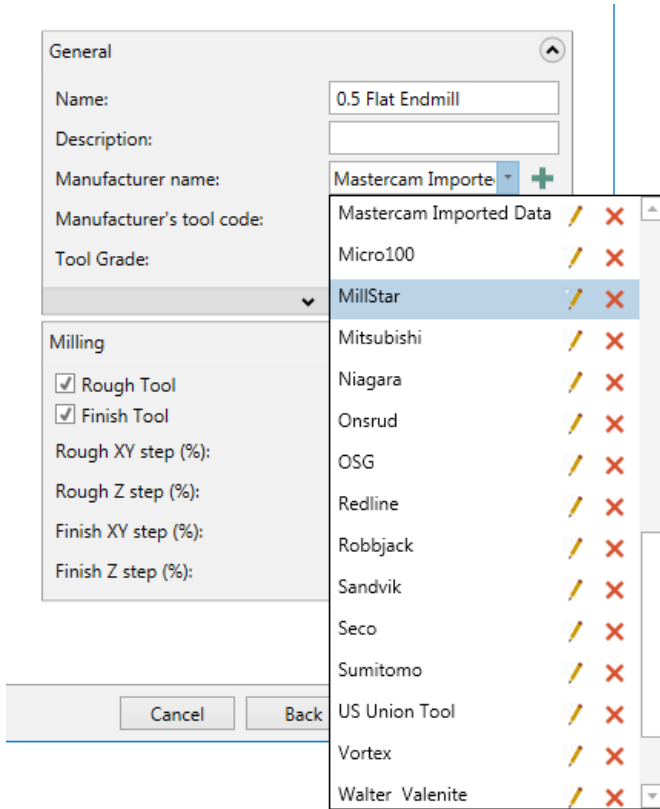

Custom Tool Display

Mastercam offers the ability to define a tool using parametric properties along with a custom profile that can be imported from a CAD file. The parametric values are used within the toolpath calculations for improved performance, especially for

complex milling operations. The optional custom profile, when provided, is used for stock model generation and collision checking in simulation.

You can now display both profiles for comparison. The default behavior is to render the custom profile as a 3D shaded tool and overlay the parametric profile using a dotted line-style.

Render Mastercam Tool

Source: Stored profile

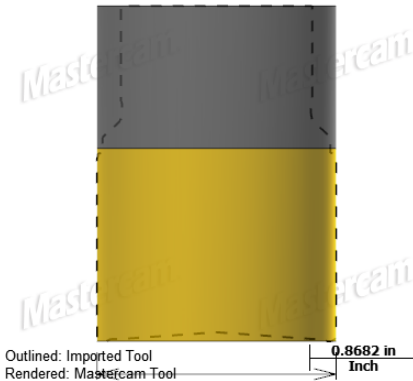

Render Imported Tool

Source: Stored profile

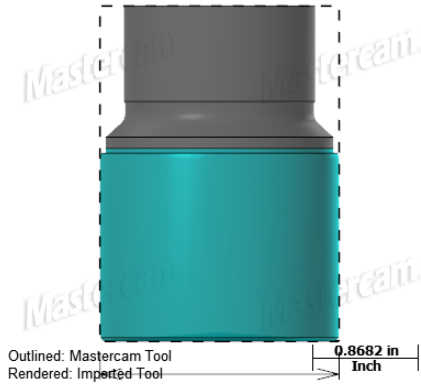

To render the parametric tool and overlay the custom profile, select the desired option shown below.

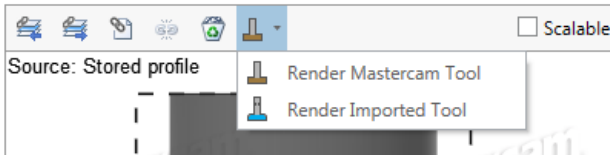

High Feed Mill Tool Type

Mastercam now supports the High Feed Mill tool type.

Define High Feed Mill

Adjust geometric properties used to define the tool shape.

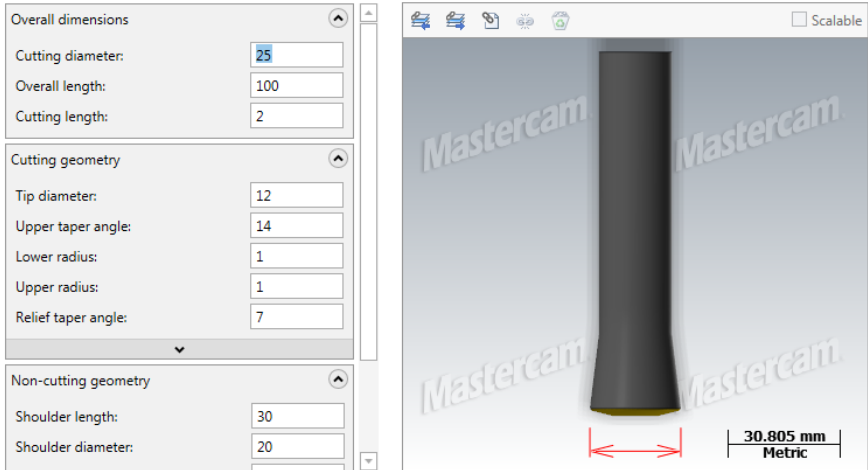

If the parametric definition does not meet your needs, or if the manufacturer provides profile data in the form of a 2D CAD file, use import option to define a custom High Feed Mill tool.

Import 3D STEP File

You can now import STEP models to generate custom tool or holder definitions. Select the **Import and link to custom geometry from a file** to select a STEP file to import.

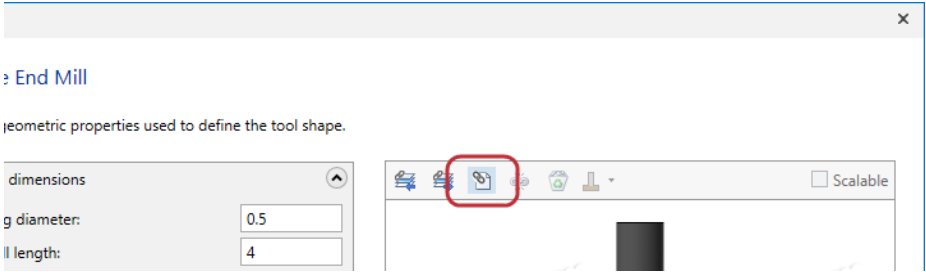

NCI Parameter for Tool Assembly Name

The 20020 NCI line now contains the name of the holder and the 20021 NCI line now contains the name of the assembly. These parameters can be accessed by the post processor or any other client of the ASCII NCI file, including .SET files.

```
Start Page 2D MORPH POCKET.NCI x
82
83 20003
84
85 20004
86 10 10 1 0 0.375 0. 0. 180. 10 10 6.332
87 20006
88 0 50. 50. 25. 25. 0. 0. 0. 0.
89 20007
90 0. 2. 3. 2.5 0.375 2. 1. 0 100. 37. 0
91 20008
92 0. 0. 1. 0 0. 0. 0 0. 0.
93 20009
94 0 0
95 20020
96 Default Holder
97 20021
98 My tool assembly
99 20800
100 0.
101 1001
102 0 100 2 10 10 10 0 713 6.4176 1 -1.043
103 0
104 0 -1.0433154 2.01825509 0.25 -2. 0
105 0
```

Overall Length

The total length of the holder is now displayed in the upper left-hand corner of the graphics view when creating a holder with the Holder Wizard.

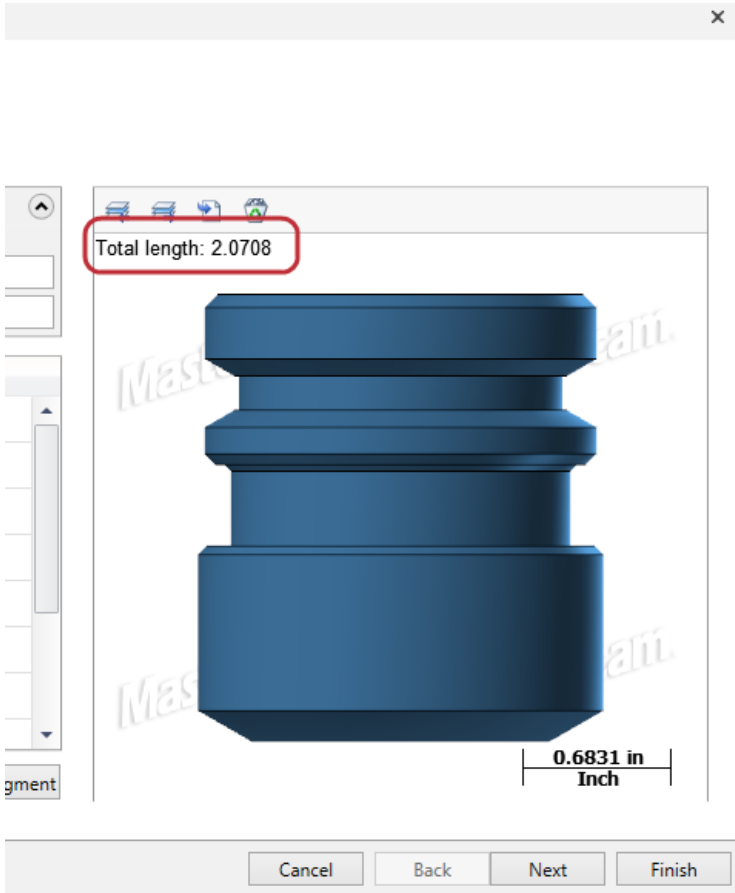

Similar Tool Warning

You can now choose to no longer display this dialog box when adding similar tools. This option only applies per Mastercam session.

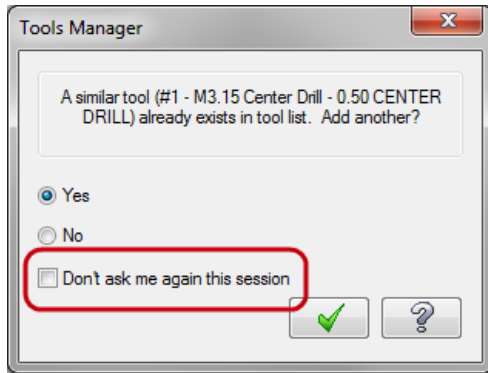

Thread Pitch

You can now override the thread pitch when working with single point thread mills for a Thread Mill toolpath.

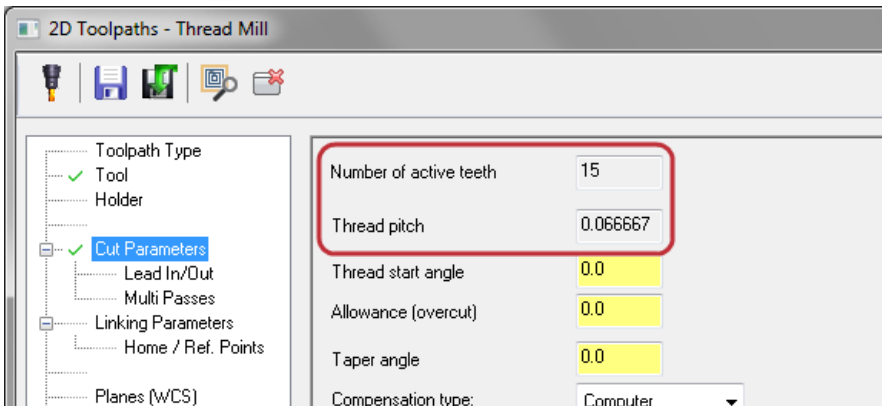

On the Cut Parameters page of a Thread Mill toolpath:

- The **Number of active teeth** parameter is disabled if the selected tool is a thread mill.
- The **Thread pitch** parameter is disabled if the selected tool is a thread mill and if the **Number of active teeth** is greater than one.
- In all other cases, both fields are enabled.

Tool List Enhancements

Column Display

You can now right-click in the column header on any tool list to hide or display columns.

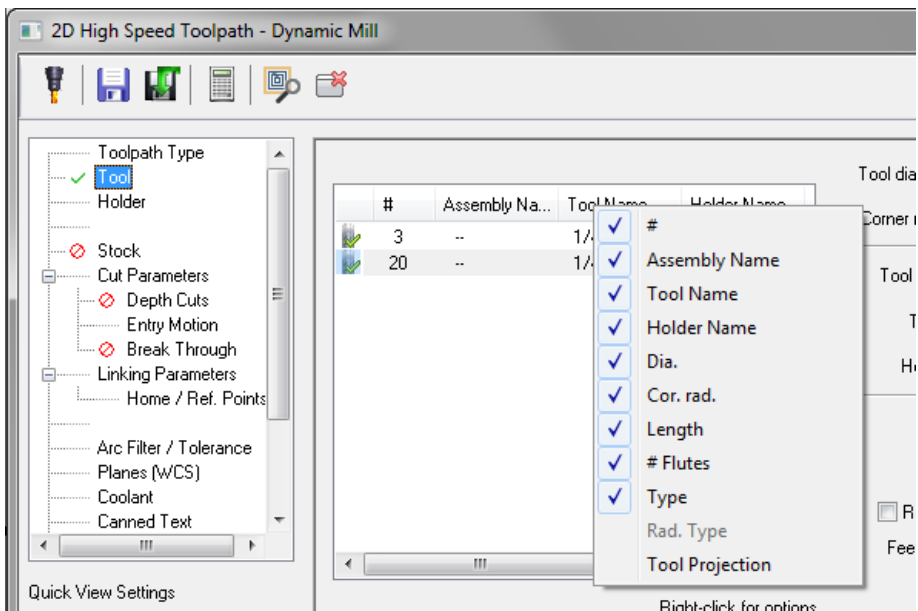

Display Mode Setting

Mastercam now retains your setting for **Display mode** in all tool lists that offer the option of showing **Tools**, **Assemblies**, or **Both**. These settings are saved separately for each list and will persist between sessions.

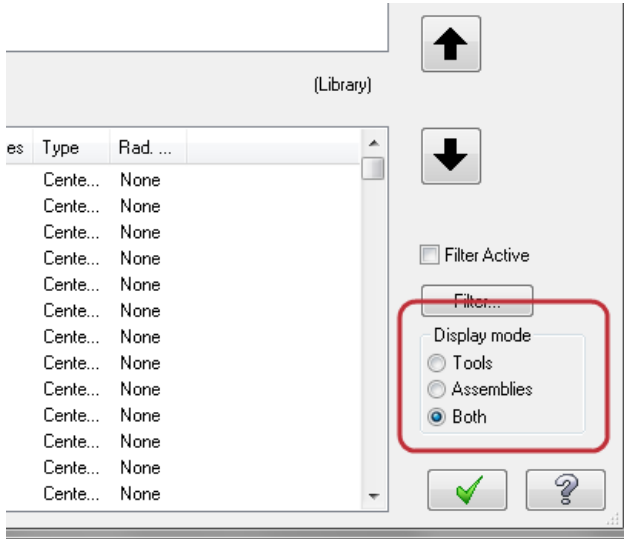

Tool Migration Warning

Mastercam's Classic Tool Manager can open and read older file formats when selecting tools from a library. However, if you make a change to a library Mastercam displays a warning that you can no longer open that file in a previous version of Mastercam.

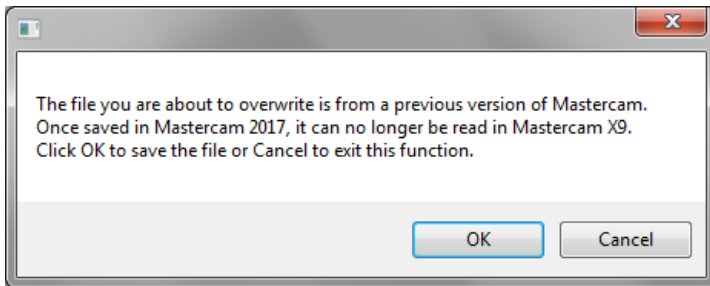

Tool Projection

You can now display your tool assembly in the graphics window and make edits to it. Right-click on a tool in the Classic Mastercam Tool Manager, in the Tool page of tree-style toolpaths, or the Toolpath parameters tab in tab-style toolpaths and select **Edit projection**.

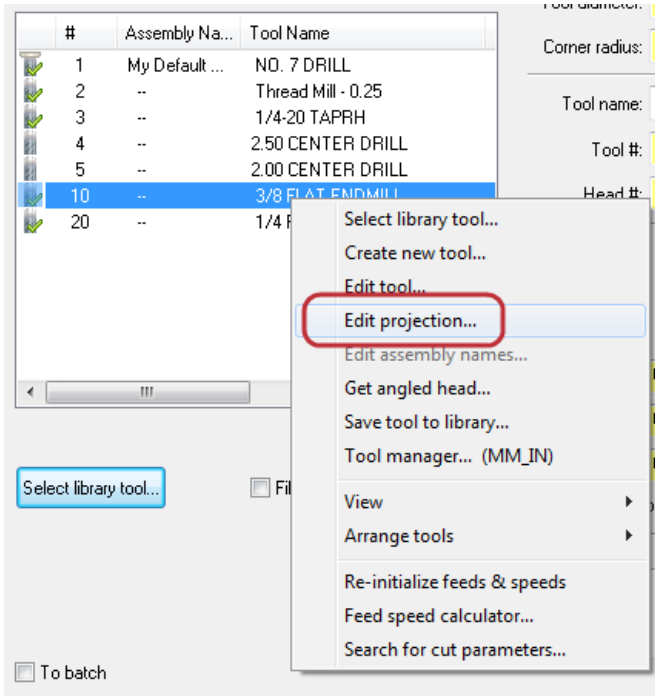

This allows you to see what the tool assembly will look like against the part you are machining. You can position it anywhere in the graphics window by clicking the projection and then clicking where you would like to place it.

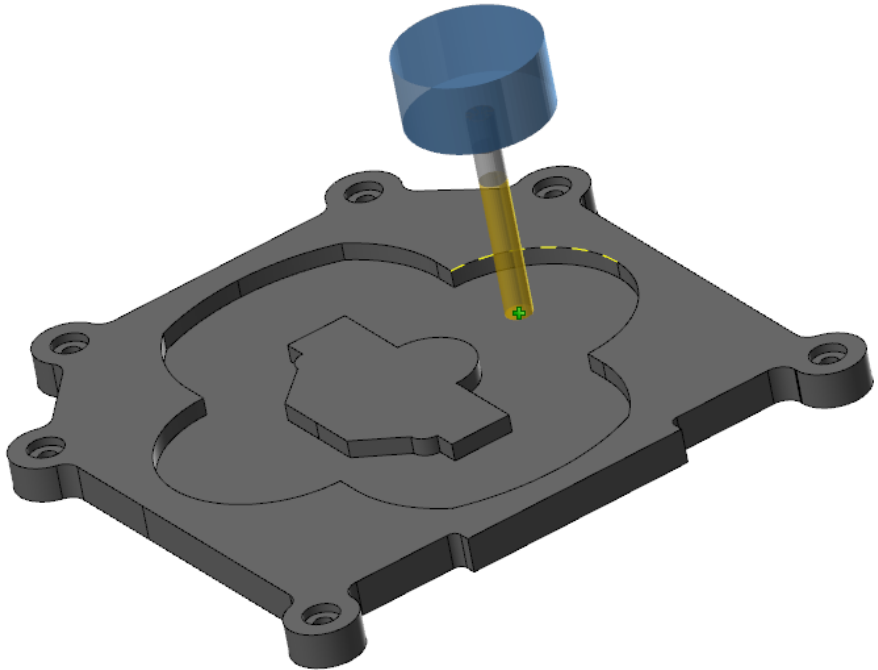

To edit the assembly, simply select the assembly and then either enter a value or use the ruler to drag it up or down to a specified length.

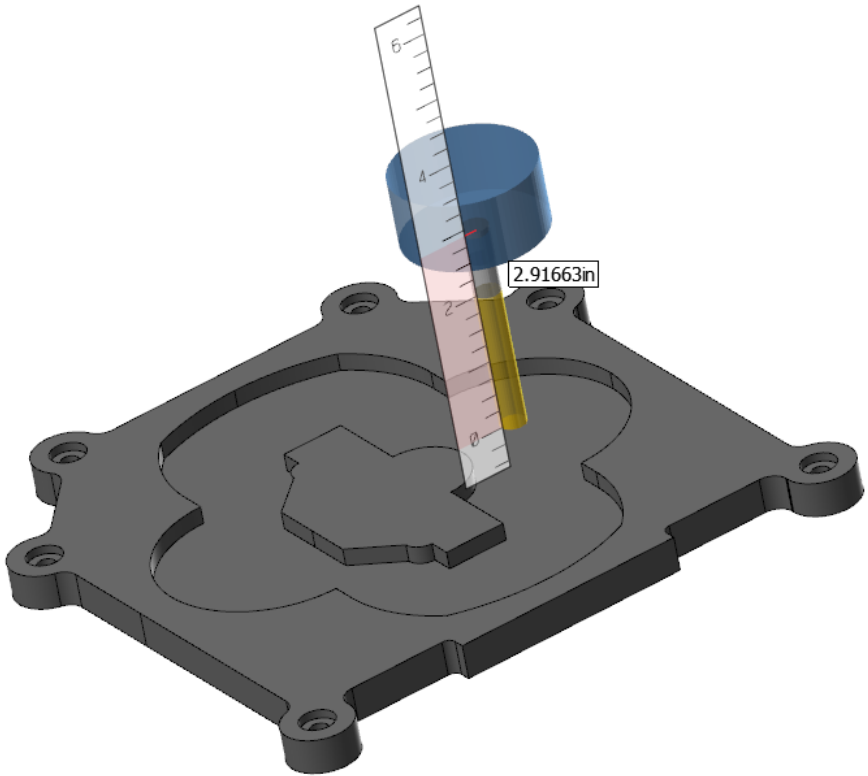

In the Planes Manager, you can also change the Tplane and the tool will change accordingly.

MILL ENHANCEMENTS

2D Enhancements

Dynamic Mill Line of Sight

Micro lifts in the Dynamic Mill toolpath now use a line-of-sight approach to move the tool where it needs to go through unobstructed areas. Listed below are some of the improvements made through these changes:

- Results in reposition moves during micro lifting that are more efficient, less complex, and travel a shorter distance
- Creates less motion, which creates smaller NC file sizes
- Improves the cycle times at the machine

Mastercam X9

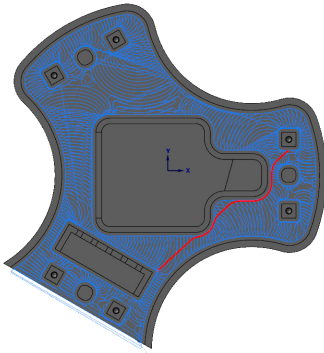

Mastercam 2017

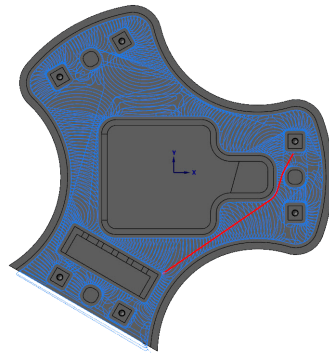

Modeless Chain Options and Chaining Dialog Box

While the Chain Options or Chaining dialog box is open, you can manipulate the graphics window view while selecting your chains.

Region Chaining Preview

You can now preview your machining regions, air regions, and containment regions for Dynamic Mill and Area Mill toolpaths. After selecting your chains, click the **Preview chains** button to view them in the graphics window.

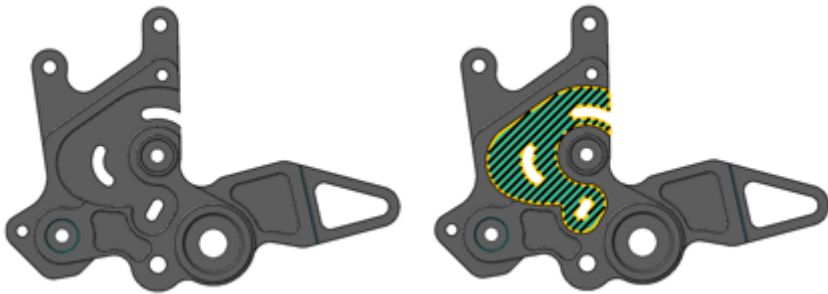

You can also change the color of the display chains to help you identify which is an air region, a machining region, and a containment region. These colors can be changed in the Colors page of the System Configuration dialog box or through the **Colors** button on the Chain Options dialog box.

Toolpath Preview

You can now preview the following 2D High Speed toolpaths in the graphics window before closing and generating or regenerating the toolpath.

- Dynamic Mill
- Area Mill
- Dynamic Contour

- Peel Mill
- Blend Mill

Click the **Preview** button in the top left corner to enable or disable the preview. You must have a tool assigned to the toolpath or the preview will not display.

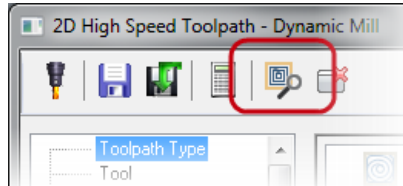

3D Enhancements

Maximum Stock Engagement

The **Maximum Stock Engagement** option on the Stock page for 3D HST Finishing toolpaths (with the exception of Horizontal Area and Pencil toolpaths) allows you to select a previously made stock model and set the maximum depth so that you can limit how deeply the cutter engages uncut material. This is particularly useful when semi-finishing a part.

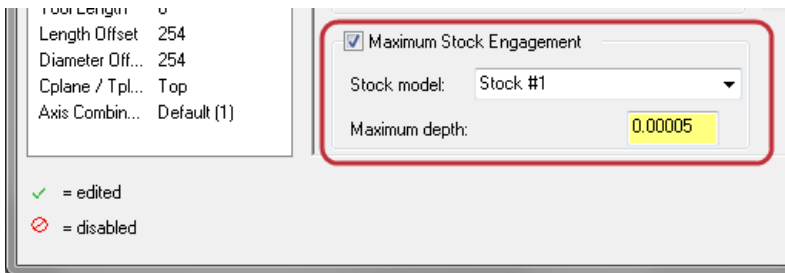

Optimized Raster Motion

The **Perpendicular fill** option on the Cut Parameters page for HST Raster allows you to limit raster passes relative to a cutoff distance of 1.4 times the **Stepover**, and then fills in the limited area with perpendicular raster motion to create a clean result.

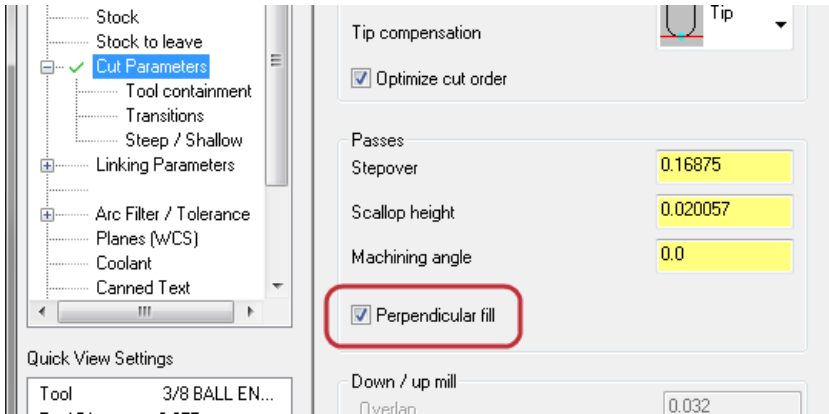

Perpendicular fill off

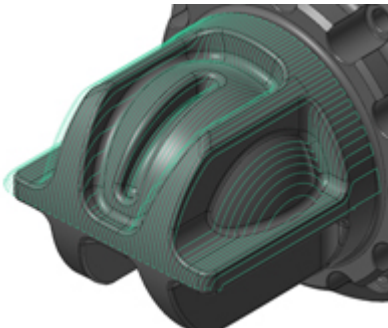

Perpendicular fill on

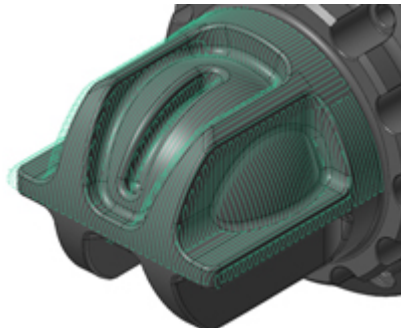

Scallop Processing Time

The processing time for 3D HST Scallop has been decreased to allow for quicker toolpath regeneration.

Trim to Stock/Rest Material Page Changes

In an effort to consolidate, the Trim to Stock and Rest Material pages have been renamed to **Stock** and moved higher up in the toolpath tree display.

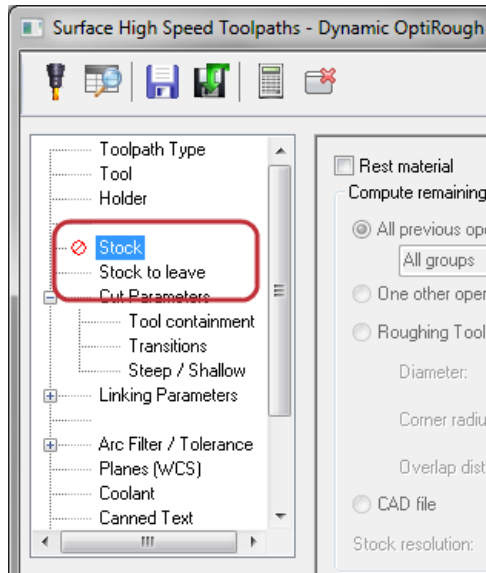

In addition, the **Stock to leave on Walls and Floors** options have been removed from the **Cut Parameters** page and placed on their own page, called **Stock to leave**, located under the Stock page.

Multiaxis Enhancements

Angle Step Value

You can now specify the **Angle Step** value on the Safety Zone page, which was previously always set to **2** degrees.

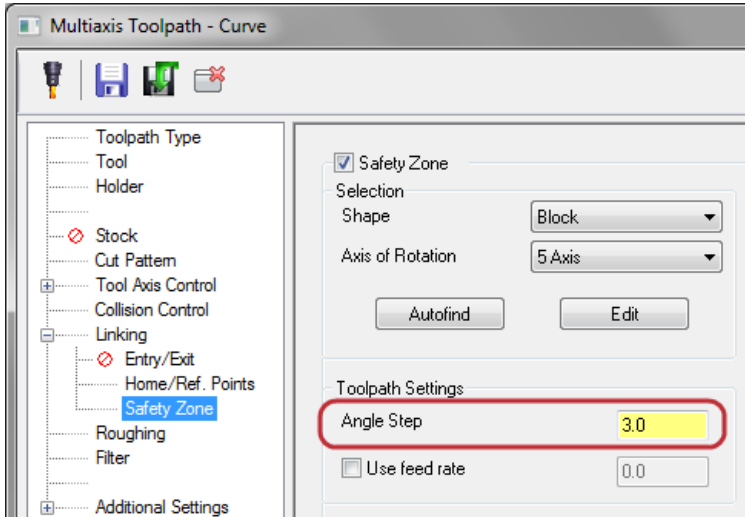

Multiaxis Drill

Multiaxis Drill has some new features, including:

- Using a line length for the drill depth.
- Association to selected geometry, removing the need for the geometry to be visible.
- Recognition of the stock model for depth and top of stock purposes.
- Selection of holes in solids using hole-axis functionality.
- Linking values relative to selected points, lines, or holes.

Interface Changes and Toolpath Consolidation

The Multiaxis toolpaths have been consolidated to reduce confusion and the overwhelming amount of toolpath options available. The following toolpaths have been consolidated or have been renamed:

Mastercam X9	Mastercam 2017
Morph between 2 curves	Morph
Morph between 2 surfaces	
Parallel to multiple curves	Parallel
Parallel to surfaces	
Parallel cuts	
Cuts Along Curve	Along Curve
MSurf	MultiSurface

The following toolpaths have been removed:

- Cavity Tilt Curve
- Cavity collision control Curve
- Projection
- Impeller Blade Swarf Finishing
- Impeller Floor Surface
- Impeller Floor Surface without Tilt Curve
- Blade root machining
- Electrode machining 4+1 Axis

The toolpaths are now grouped by either a **Pattern** or **Application** toolpath type. Pattern toolpaths are general toolpaths that can be used in a variety of ways to

manufacture your part. Application toolpaths are designed to solve particular machining problems while automating some of the processes.

Mastercam X9

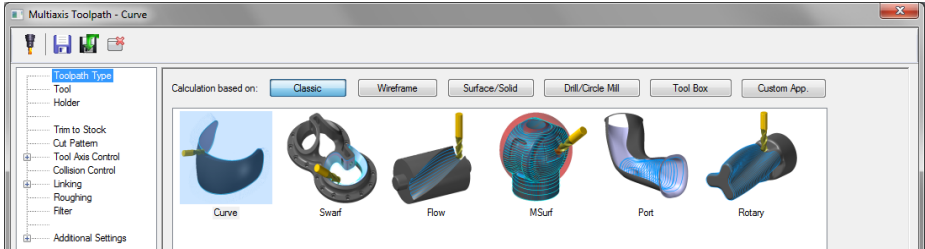

Mastercam 2017

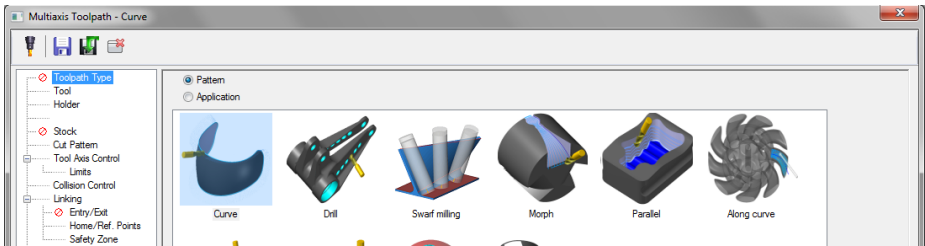

Point and Line Associativity

Point and lines selected for tool axis control will now be associated with the toolpaths in which they are used. The Point, Line, and Advanced Options sub-branches have been removed when selecting these entities.

Point Sorting

Point sorting is now available for Multiaxis Drill and Circle Mill toolpaths. Select Sorting from the Drill Point Selection dialog box to access the sorting controls. You may also change the sorting options through the toolpath's parameters. The same sorting options used in 2D/3D toolpaths are now available in select Multiaxis toolpaths.

Roughing Page Consolidation

The Roughing page has been condensed so all common options are available on a single page. Depth cuts, multi passes, morph pocket, and sorting can now be found on the Roughing page.

Rotary Advanced

Mastercam's Multiaxis package now includes a new 4-axis toolpath - Rotary Advanced. This powerful toolpath allows more control over the tool motion through the selection of walls, hubs, and shroud surfaces. Define your stock, select your part geometry, set collision control options, and adjust linking moves to quickly create motion on complex parts. Rough or Finish your rotary 4-axis using Rotary Advanced.

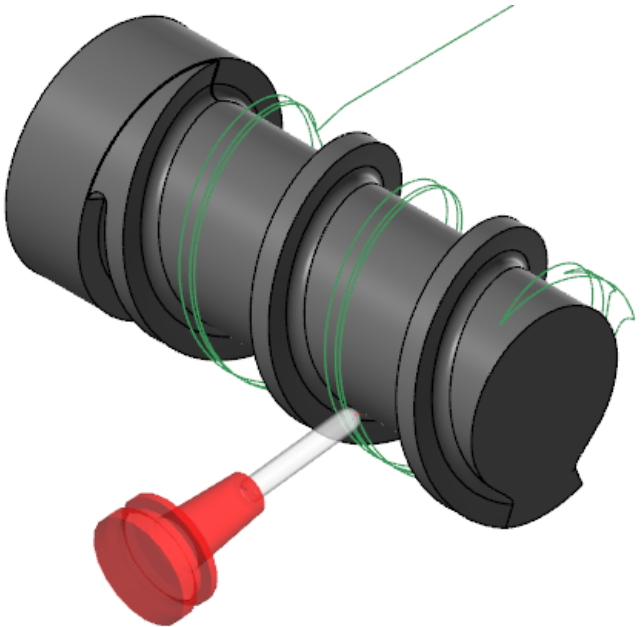

Stock Page Consolidation

The various ways of selecting stock have been updated to have consistent workflow and selection methods. The Trim to Stock, Rest Material, and Stock definition pages have been renamed to the Stock page. An icon now displays if Stock is turned on or off, similar to 3-axis toolpaths.

In the Stock page, you can now select the **Job Setup** option to use stock already defined in the Machine Group Properties dialog box.

LATHE ENHANCEMENTS

Align Solid Body (Lathe)

This function has been added to Lathe which simplifies the process of aligning solid models for turning. It has also been added to Mill-Turn ("[Align Solid Body \(Mill-Turn\)](#)" on page 121).

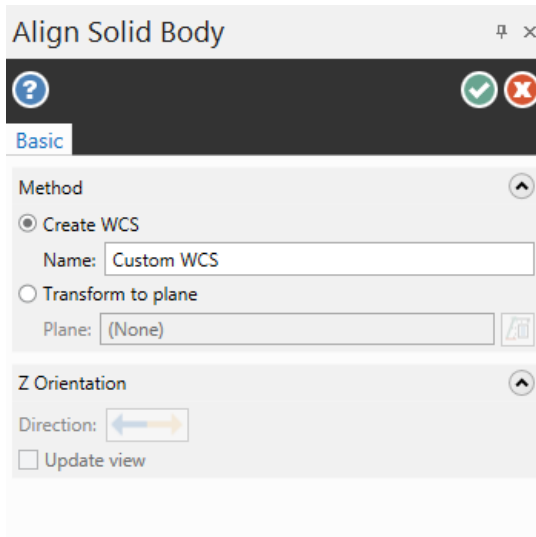

You define the center of the rotation for the part and select the appropriate geometry. Mastercam will then rotate to an Isometric view, where you can use the dynamic gnomon to adjust the origin.

You can then create a WCS, leaving the part where it exists in space, or you can transform the part to a plane you select.

This function is found on the **Lathe Turning** contextual tab, shown below.

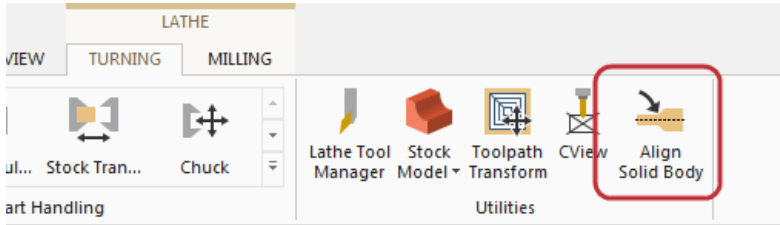

Chip Break

A new option and dialog box has been added to the Lathe Rough and Lathe Contour Rough toolpaths to establish when chip breaks occur. It is located on the Rough parameters and Contour rough parameters tabs, respectively. Select the checkbox and click **Chip Break** to open the dialog box.

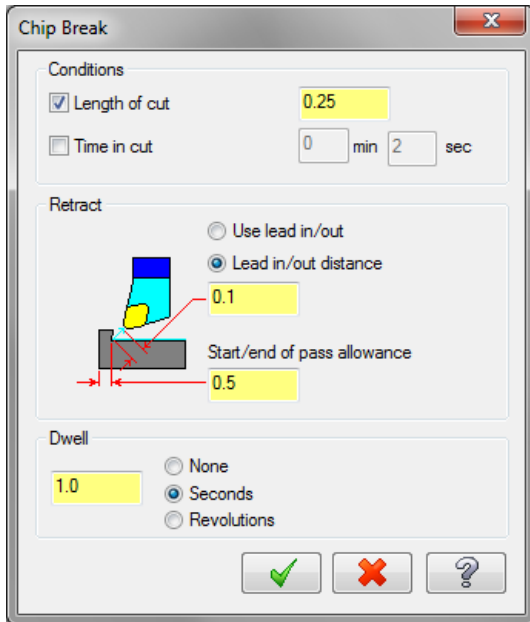

This is valuable when working with stringy materials, such as aluminum or plastic, and allows you to set length and time conditions, retract, and dwell options.

Chip Break Off

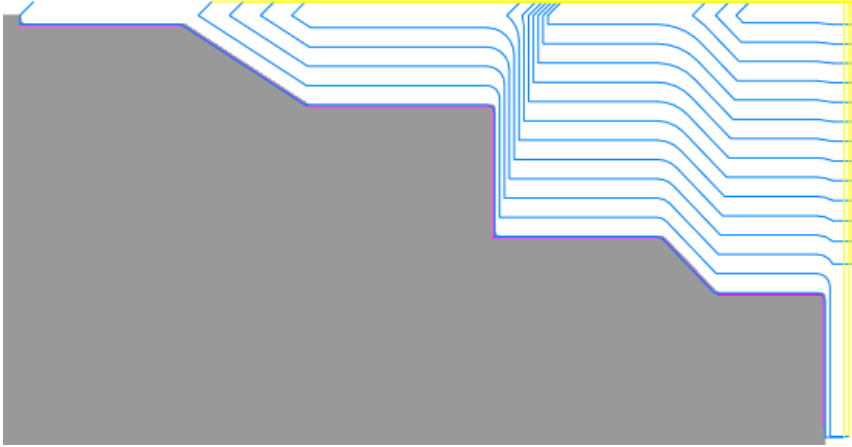

Chip Break On

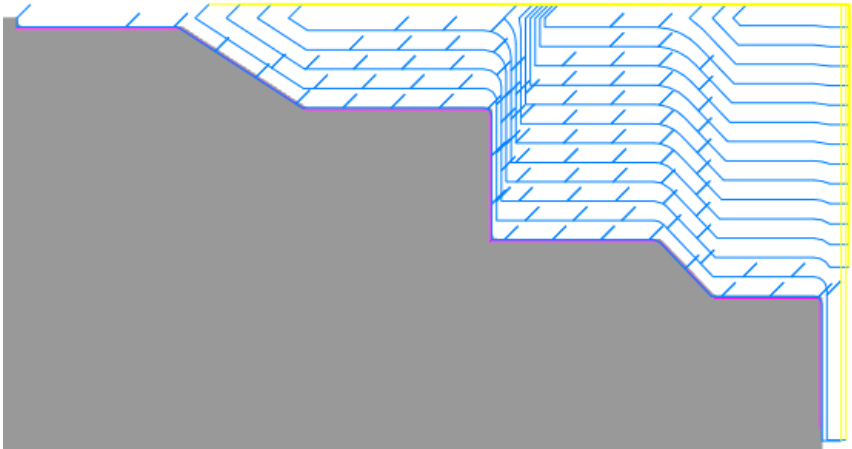

Lathe Plane Enhancements

The process of selecting the tool plane, origin, and display mode has been simplified in Lathe operations. The Coordinates button, which appeared on the Toolpath parameters tab, has been removed and all functionality has been moved to the Axis Combination/Spindle Origin dialog box.

Mastercam X9

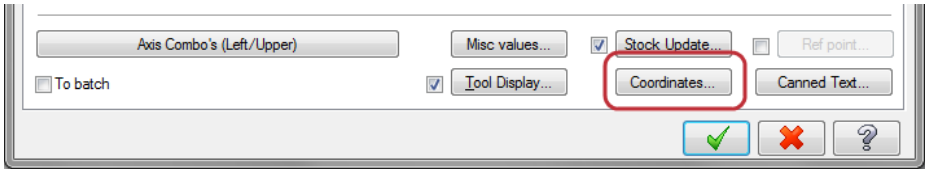

Mastercam 2017

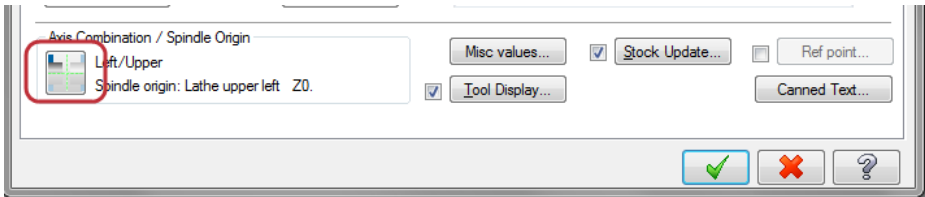

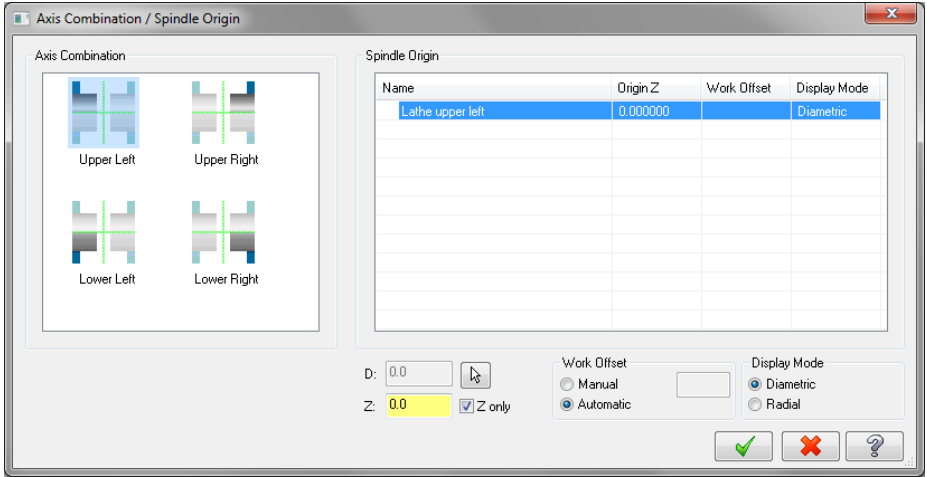

The new Axis Combination / Spindle Origin dialog box filters available tool planes, displaying only those planes with the correct orientation for the selected axis combination.

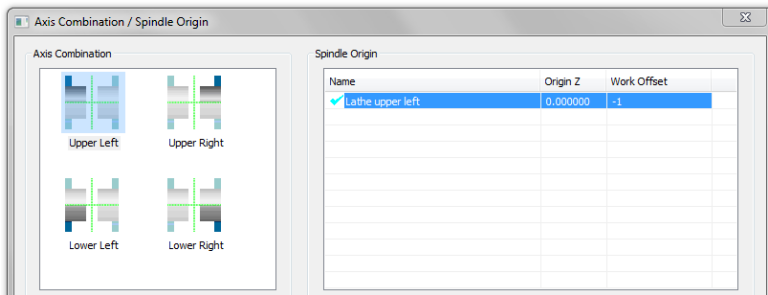

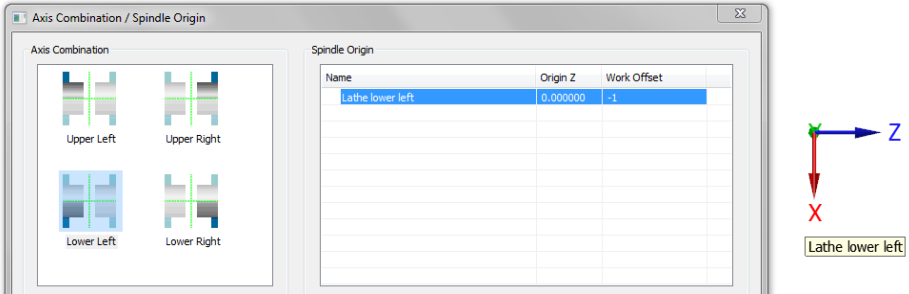

You can also right-click in the Spindle Origin list to create a new tool plane or rename a tool plane.

Display Mode

Mastercam includes Lathe construction planes that let you work in radius or diameter coordinates. The construction plane affects the drawing mode for geometry creation. The construction plane also affects the display mode, altering the input fields for items such as Home Position and Reference Points.

An option has been added to the Axis Combination / Spindle Origin dialog box, which allows you to quickly and easily determine if data should be entered diametrically or radially when a given plane is used in an operation.

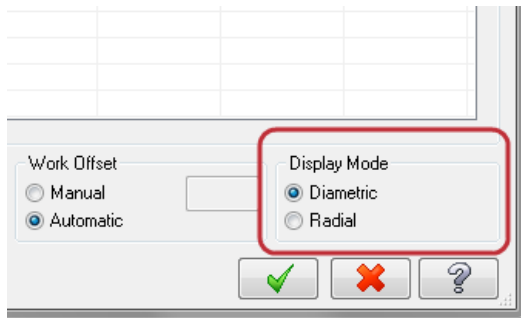

The active construction plane is used to determine the default setting for the Display Mode when the first Lathe toolpath is created. If the plane is set to one of the diametric Lathe planes, the setting in the Axis Combination / Spindle Origin dialog box will match.

Previous Mastercam version files will retain the settings used in the respective planes used in lathe operations. This can then be used to modify the Display Mode.

Lathe Stock Model Enhancements

Lathe Stock Model operations now allow you to manipulate the Lathe stock boundary using Mill operations.

The **Lathe operation** option allows you to select a previous Lathe operation as the source of the stock shape by reading the stock boundary contained in it.

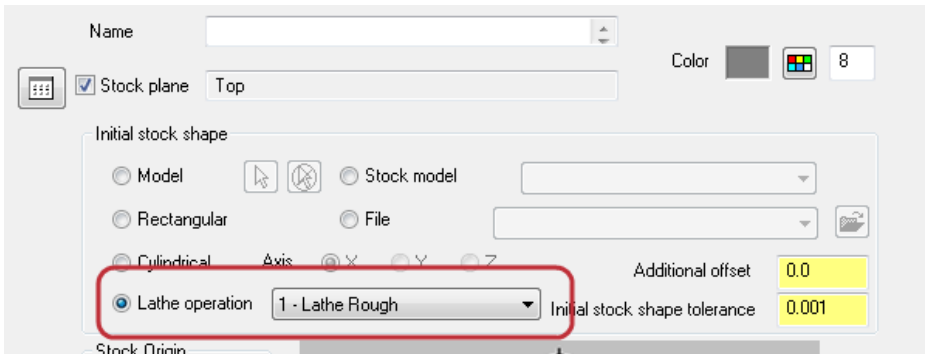

The **Create stock boundary** option lets you create a new Lathe stock boundary using the spun profile of the stock model.

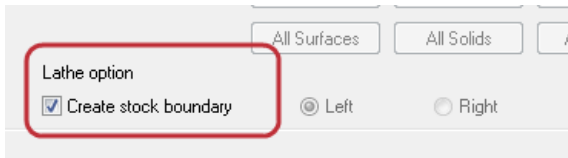

TNRC Control for B-Axis Turning Operations

The Tool Angle dialog box contains new options, which were previously only available for Mill-Turn operations. Select the **Tool Angle** button on the Toolpath parameters page to open this dialog box.

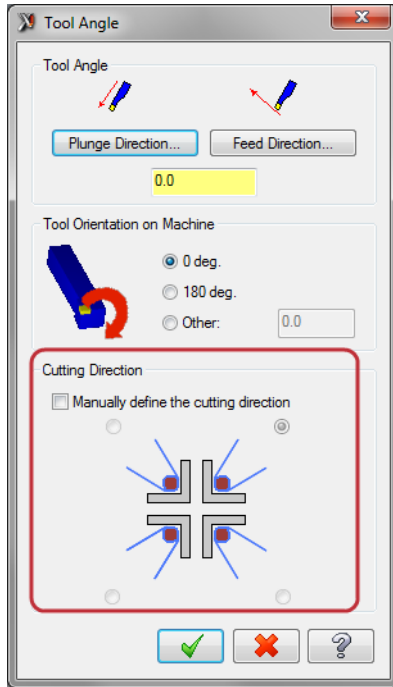

These options tell Mastercam which quadrant you used to touch off your tool. If you are creating a toolpath and the tool's control point is not where you want, you can use these options to swap it. Select the **Manually define the cutting direction** checkbox and choose the option that matches how the tool was touched off on the machine.

MILL-TURN ENHANCEMENTS

Align Solid Body (Mill-Turn)

The Align Solid Body function, which was added for Lathe ("[Align Solid Body \(Lathe\)](#)" on page 113), is also available for Mill-Turn. This function has been added as part of the Job Setup process, simplifying the setting of the WCS when off-axis work pieces are encountered.

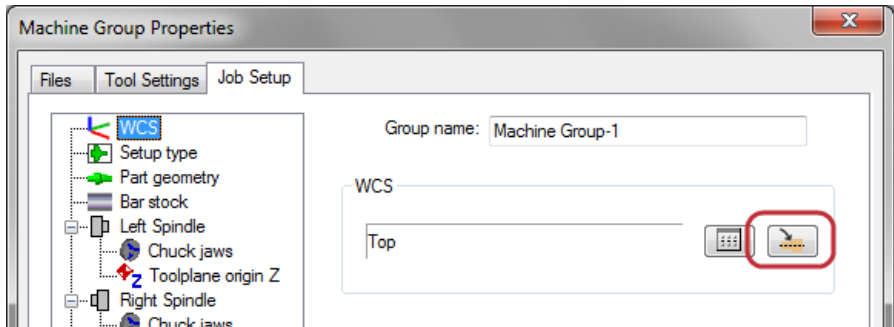

This function also appears on the **Mill-Turn Turning** contextual tab, allowing for the manipulation of other solids following the Job Setup process.

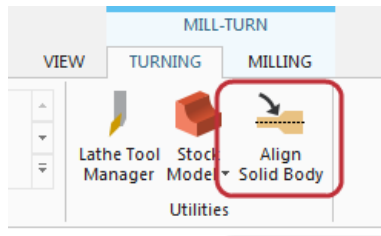

Application Guides in .machine Files

Every Mill-Turn machine solution includes a comprehensive application guide which documents machine-specific information on setting up tools, token settings, and other valuable information. The application guides are provided in PDF format and are part of the .machine file.

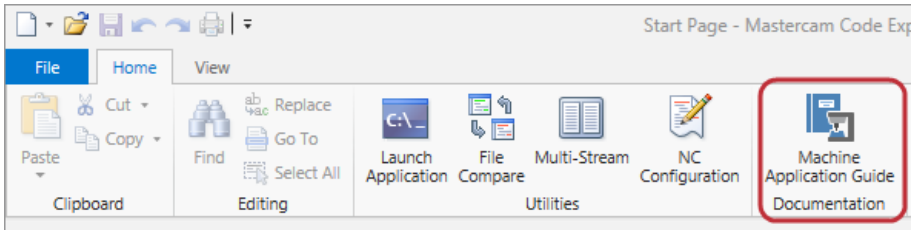

Select **Machine Application Guide** on the **Home** tab in Code Expert to launch an application guide specific to your current machine.

Job Setup Enhancements

Improved Handling of Position Changes

Changes to values such as **Part Stickout**, **Pickoff Position**, or **Jaw Dimensions** no longer result in associated geometry being deleted and recreated. All geometry associated with Job Setup and operations in the Machine Group will now be moved to their new location when the operations are regenerated.

Improved Handling of Complex Part Geometry

Job Setup now uses a process similar to Transform, where the selected part geometry and turn profile are created when the Job Setup process is completed. While it is processing, Job Setup uses a wireframe representation. This results in improved performance.

Machine File Version Properties

We have added version information into Mill-Turn machine files (set by machine developers). This information is now accessible through the File properties in Windows.



Multi-Sessions and Multi-Machine Group Support

Mastercam Mill-Turn now supports multiple sessions and multiple Machine Groups. Each Mill-Turn Machine Group will be matched with a unique session of Code Expert and Simulation.

Multi-Station Tool Locators for Turrets

Mill-Turn now supports multi-station tool locators for turrets, as well as half index positions. Tool locator positions are set in the turret setup which has been redesigned. Enter information for index positions, mounting locations, and several other options, including if half index locations exist.

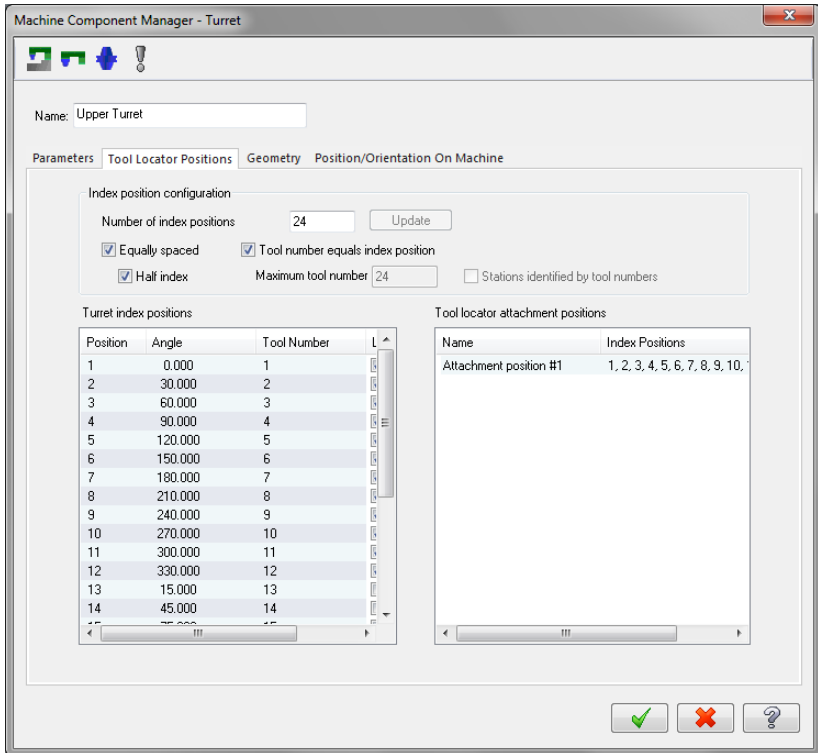

The tool locator components are now able to be mounted on available attachment positions. Options are available to define individual stations within the tool locator. A field for projection adjustment is also provided.

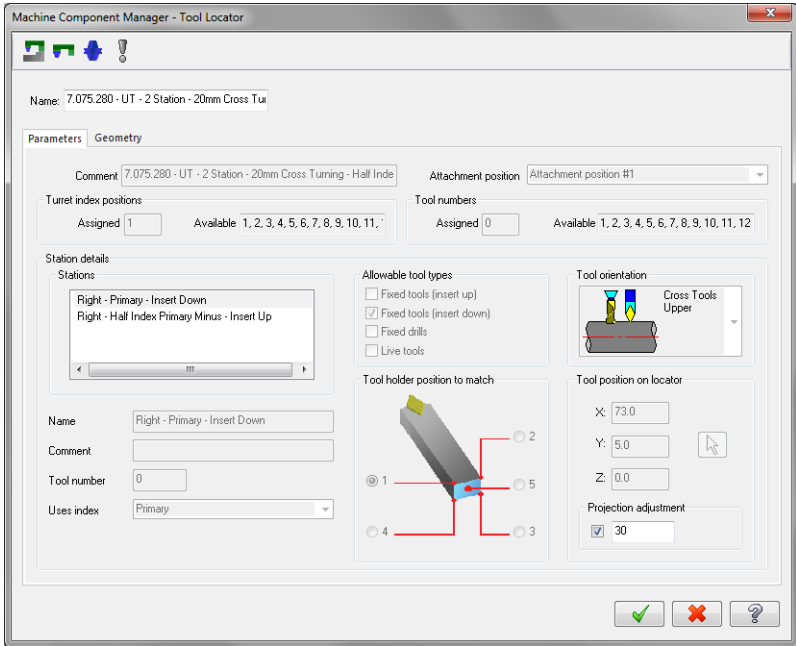

The Tool Setup Manager has been redesigned to improve workflow and ease of use:

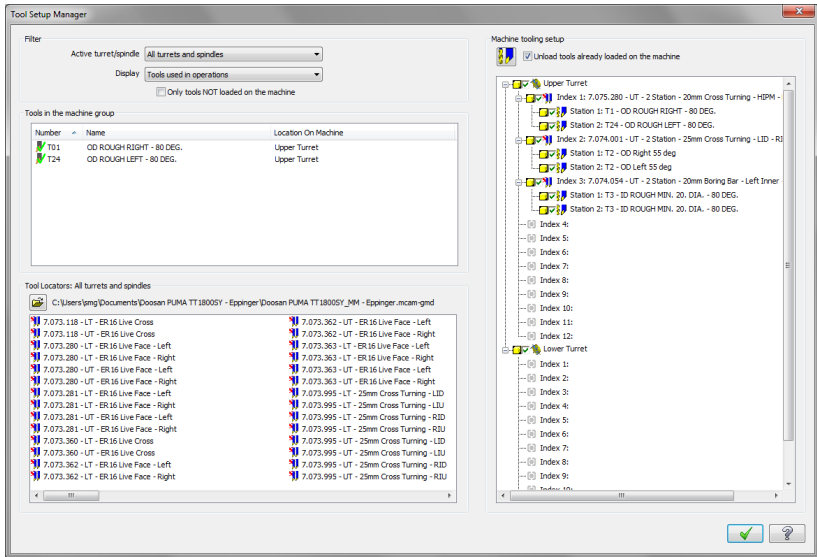

- The Filter group streamlines the items listed, reducing clutter.
- Tooltips have been added to the tool locator components, providing easy access to information.
- Edit a tool within the Tool Setup Manager by selecting **Edit Tool** from the right-click menu.
- Mountable index positions have been added to the Machine tooling setup, representing available locators and stations where tools can be loaded. Use the **Remove and reload all tools** button to do this for you automatically.

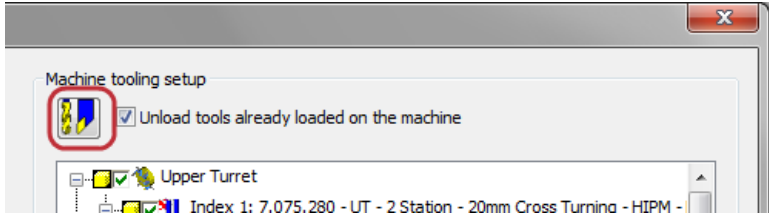

- Drag and drop loaded tools between stations, allowing for quick and easy location changes.
- Use the right-click menu in the display list to view the components in the graphics view.

Tool Setup Manager communicates directly to Machine Simulator, allowing you to see your tool locators, stations, and mounted tools.

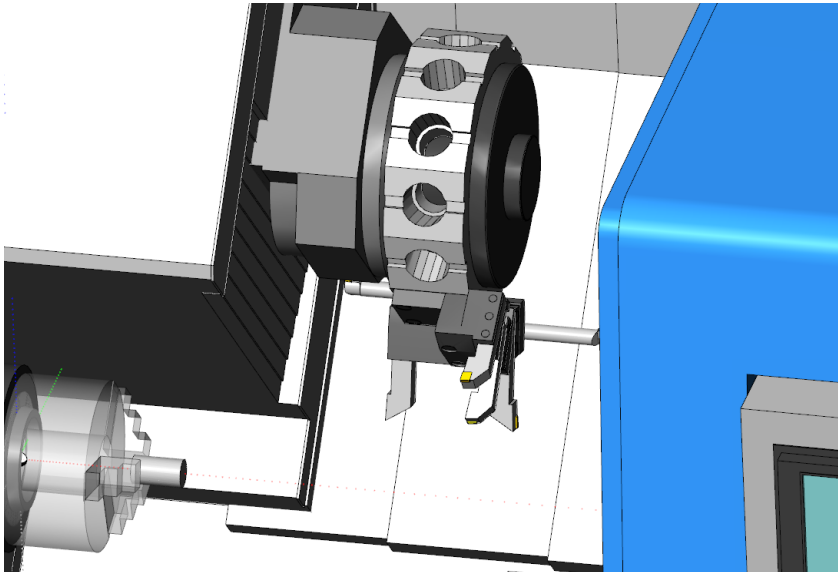

Reference Positions Enhancements

Allow Multiple Reference Return Locations

Mastercam Mill-Turn now supports multiple reference return locations for machines such as the Okuma Multus, which allow the user to utilize up to eight different reference return locations. When multiple reference return locations are available, one can be selected as the default for use in each stream of output. We have also added the ability to define a string for output in the NC code, allowing for localization for the reference position name without changing the output in the NC file.

Add Optional Default Reference Position in POCO

Mastercam Mill-Turn Pickoff and Cutoff (POCO) processes now support default reference positions for use in the transfer process. This functionality is useful for machines where the default reference return location may not be usable once the pickoff spindle has been moved, allowing safe positions to be defined and used for turret tool changes.

View Control Options for Sync Manager

Sync Manager View options in the right-click menu have been expanded to support **Zoom Window**, **Unzoom 80%**, and **Dynamic Rotation**.

Mastercam X9

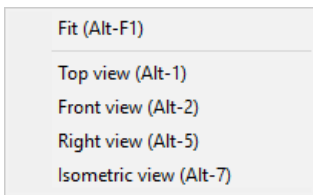

Mastercam 2017

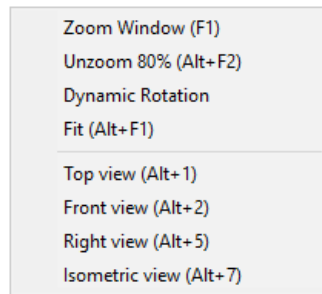

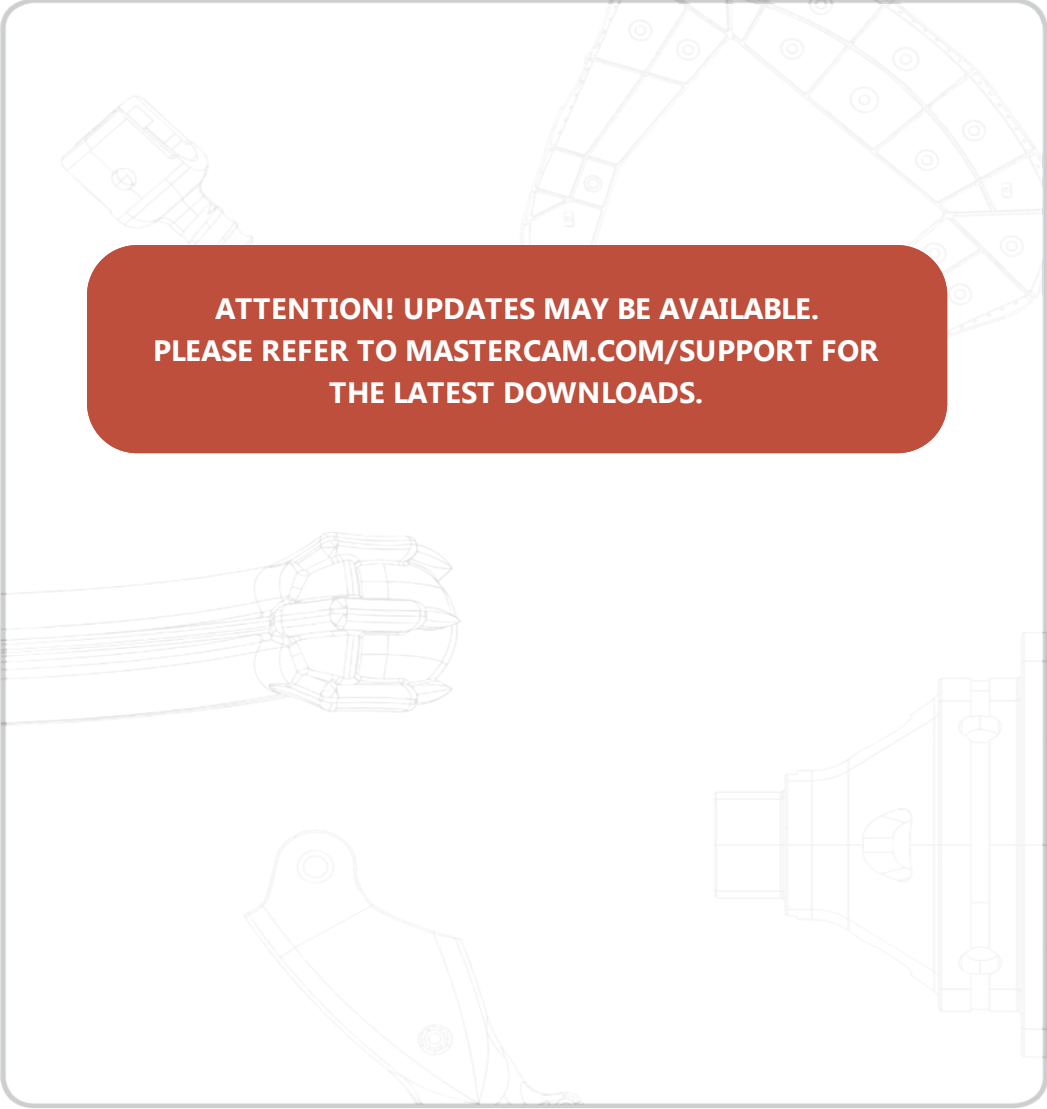

**ATTENTION! UPDATES MAY BE AVAILABLE.
PLEASE REFER TO MASTERCAM.COM/SUPPORT FOR
THE LATEST DOWNLOADS.**

CNC Software, Inc.

671 Old Post Road

Tolland, CT 06084 USA



www.mastercam.com

Mastercam[®]
Be Dynamic.

*Mastercam[®] is a registered trademark of CNC Software, Inc. © 1983-2016. All rights reserved.
All other trademarks are property of their respective owners.*